

# Watson & Hillhouse

Unrivalled Service in Piling Equipment Supply Since 1972



## **KOWAN STILL WORKER** Noise and Vibration Free Environmentally Friendly Pile Pressing Machines

Global Agents - Available for Hire and Sale



### Features and Benefits of the Still Worker

- Virtually noise and vibration free means installation of steel piles as close as 50cm to existing structures or services
- Exclusive mast tilt/self traveller ensures a more efficient safer operation
- Operates at ground level with no piling gates making it a very safe method of operation
- Wireless radio control providing a broad range of vision for the operator and a safe working environment
- Light and compact requiring only a small crane for pile pitching
- Ideal for height restricted sites



## Start

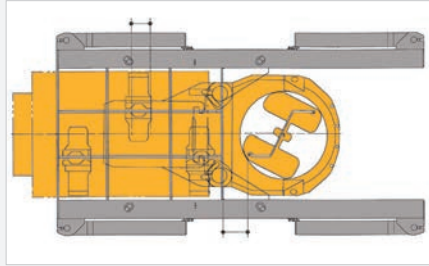
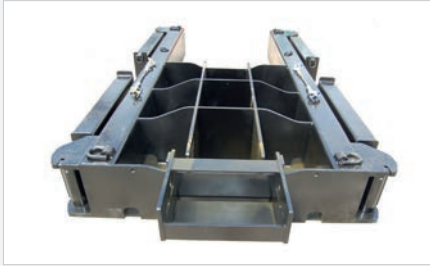

The Still Worker is set on a reaction stand with kentledge in the form of piles, concrete or steel weights. The first four sheet piles are then pressed in from the stand.

## Self Travel

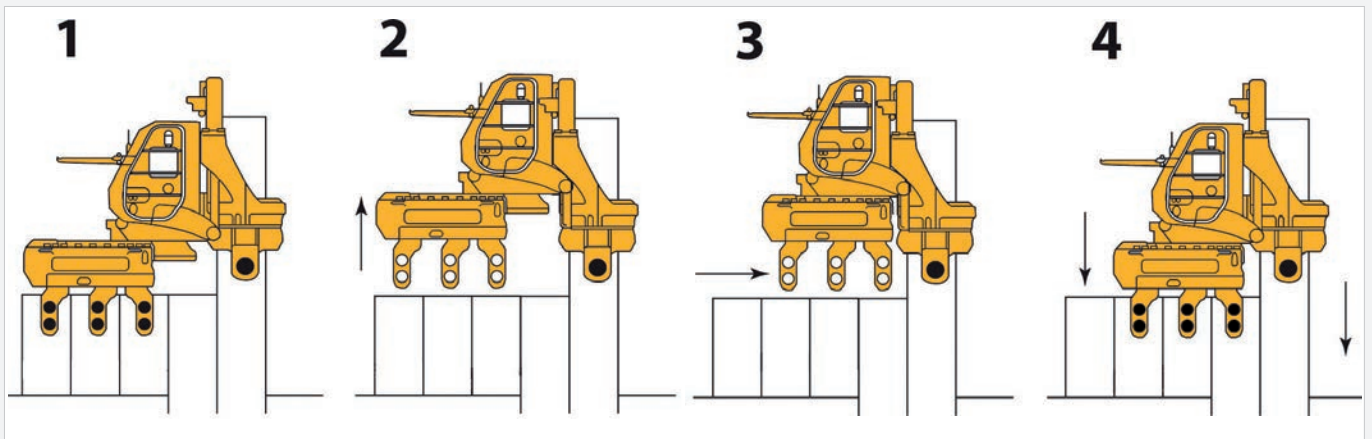

The Still Worker moves by elevating its travel carriage while supporting itself on the last installed pile. The travel carriage then slides forward and lowers itself, drops onto the installed sheet piles and continues its hydraulic installation process. After the fourth pile is driven, the Still Worker will have walked off the reaction stand and will be using the installed piles as reaction.

## Corners

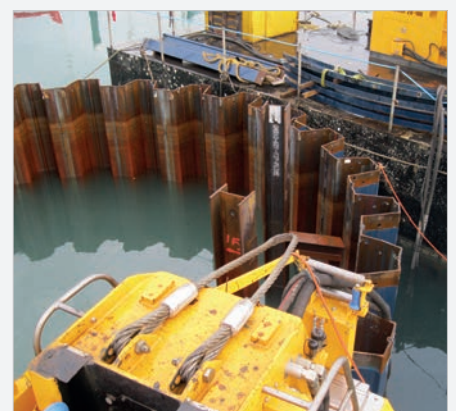
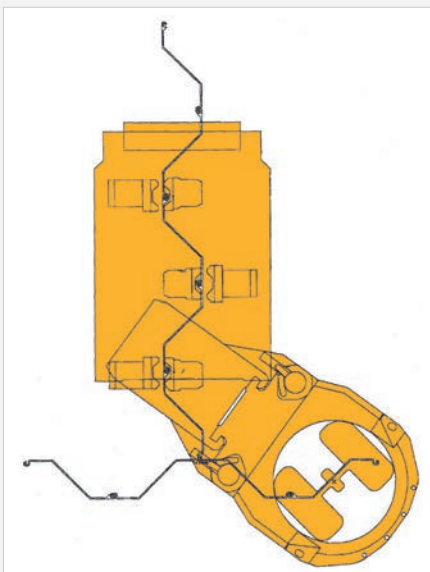

The Still Worker presses in the dummy piles then uses these to work from, extracting them at a later date.



### Mast Tilt And Self Leveller

Exclusive mast tilt function 5 degrees inclination forwards and backwards.



- Mast tilt for precision - Gives the operator an additional correction function for pile verticality and enables working on gradients.
- Mast tilt for productivity - The self travel manoeuvre is fast and efficient; the operator maintains machine verticality after each manoeuvre with the touch of a button.
- Mast tilt for safety - Self levelling eliminates the unsafe practice of chocking up the chassis/clamps with wedges.

### Self Travel Support System

Both the ZU-100 and WP-150 are now fitted with the self travel support system (STSS) eliminating the use of the self travel bar.





**NO  
WORKING  
AT HEIGHT**

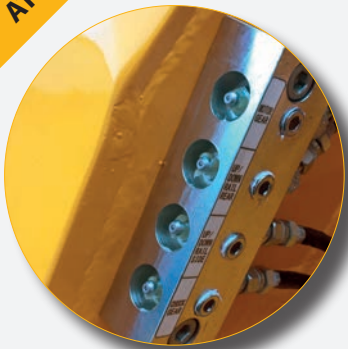

### Low Level Grease Points

Low level grease points makes daily maintenance easier and safer for the operator.

### Low Level Stowage

No "working at height" issues with low level lifting equipment stowage on the power pack and Still Worker main unit.



### Mast and slide base protection

The press in force is restricted at the top of the mast, and when the slide base is extended, to prevent excessive wear and damage to prolong the life and reduce owner costs.

### Press-in Force Limiter

Set the required press-in force for the job via the radio control unit to protect from over use and prolong the life of the machine.





### Kowan Press-in Monitoring System

- Input soil data; SPT/N values
- Records press-in force - time data
- Records press-in force - depth data
- Records press-in force - mast tilt position - time and depth
- USB data storage
- Digital machine monitor
- Tough pad option
- Printout
- Remote access and live monitoring

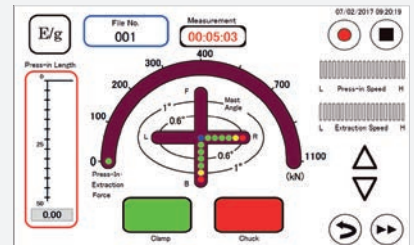
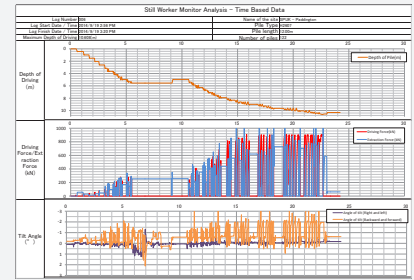

MS Engine Speed 1798.5 min<sup>-1</sup>

Intake Air Temp	6 °C	DPF Soot Load	40 %
Coolant Temp	81 °C	DEF Tank Level	43.2 %
Hydraulic Oil Temp	19 °C	Engine Hour	25.5 h
Battery Power	27.7 V		

### Kowan Data Logger

- Chuck up/down position
- Chuck open/closed data
- Clamps open/closed data
- Drive/extraction tonnage

### Kowan Power Pack/Engine Data Logger

- Records and monitors engine functions





## Options And Features



Standard mode



Water jet mode with water jet reel



Water jet mode with steel lance



Auger crush mode



Hydraulic walk back device



Work over water



Staging for river works



Crawler mounted power pack



Point laser

## WP-150

Max pressing in force	kN	1500
Max drawing out force	kN	1600
Stroke	mm	800
Pressing in speed	m/min	1.8-23.0
Drawing out speed	m/min	1.9-18.0
Tilting device	degrees	+/-5
Mast rotation	degrees	180
Applicable sheet piles	mm	'U' 400 - 600
Operation system		Wireless radio control & cable remote control
Moving system		Self-moving
Oil/Greases		Biodegradable
Weight	kg	9,970

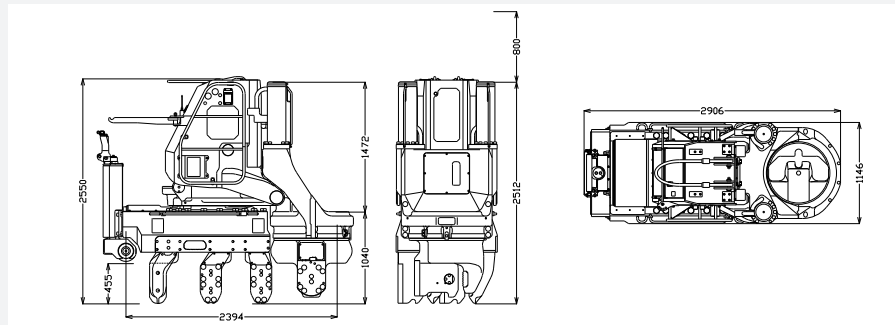

## ZU-100

Max pressing in force	kN	1000
Max drawing out force	kN	1100
Stroke	mm	750
Pressing in speed	m/min	3.0-36.0
Drawing out speed	m/min	2.4-28.0
Tilting device	degrees	+/-5
Mast rotation	degrees	180
Applicable sheet piles	mm	'Z' 575-708 & 'U' 600-750
Operation system		Wireless radio control & cable remote control
Moving system		Self-moving
Oil/Greases		Biodegradable
Weight	kg	12,260

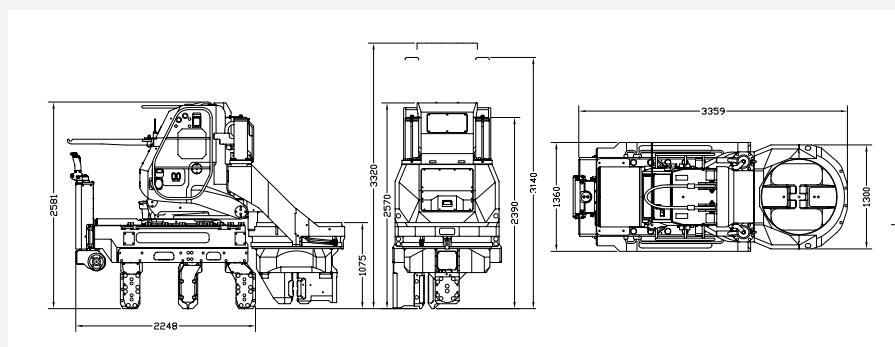

## Reaction Stand

		WP	ZU
Length (L1)	mm	3200	4000
Length (L2)	mm	5465	6385
Width (W1)	mm	2000	2200
Width (W2)	mm	4220	4640
Height	mm	475	462
Weight	kg	1700	2400

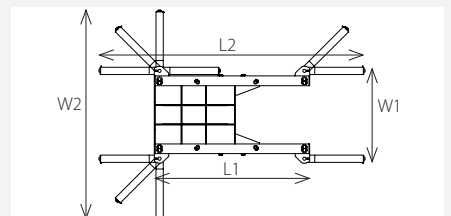



## NEO400α with auger crush

Max pressing in force	kN	800
Max drawing out force	kN	900
Stroke	mm	1000
Pressing in speed	m/min	4.2-39.0
Drawing out speed	m/min	3.0-29.0
Positioning control method		Leader mast tilting
Applicable sheet piles	mm	'U' 400, 500, 600
Applicable tube piles		N/A
Operation system		Wireless radio control
Moving system		Self-moving
Weight	kg	11,150
Auger		AC-4700
Applicable sheet pile length	m	21m (max.)
Auger weight	kg	2000
Casing weight	kg	7750 pile length 21 m

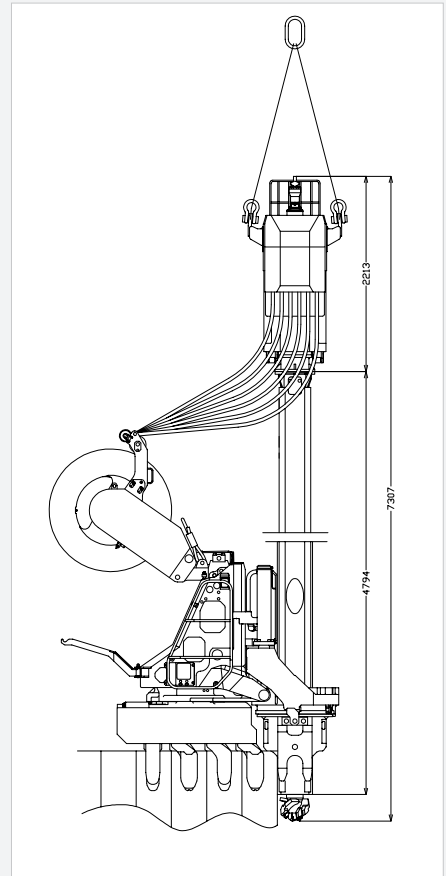

## NEO 100

Max pressing in force	kN	1000
Max drawing out force	kN	1100
Stroke	mm	750
Pressing in speed	m/min	3.0-36.0
Drawing out speed	m/min	2.4-28.0
Positioning control method		Leader mast tilting
Applicable sheet piles	mm	'U' 400
Applicable tube piles		N/A
Operating system		Wireless radio-control
Moving system		Self travelling
Weight 4 Clamp	kg	5800
Weight 3 Clamp	kg	5300

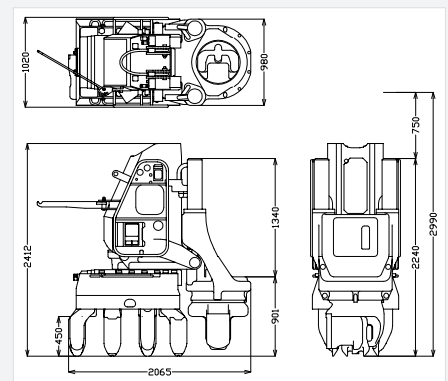

## NEO 100 W

Max pressing in force	kN	1000
Max drawing out force	kN	1100
Stroke	mm	750
Pressing in speed	m/min	3.0-36.0
Drawing out speed	m/min	2.4-28.0
Positioning control method		Leader mast tilting
Applicable sheet piles	mm	'U' 400-600
Applicable tube piles		N/A
Operating system		Wireless radio-control
Moving system		Self travelling
Weight	kg	7400

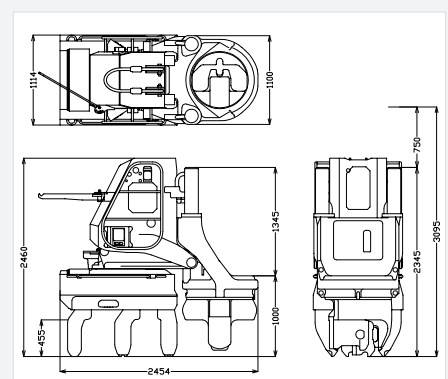



## PZ1200 & PZ1500

		PZ1200	PZ1500
Max pressing in force	kN	1500	2000
Max drawing out force	kN	1600	2100
Stroke	mm	950	1000
Pressing in speed	m/min	1.9-19.0	1.1-15.0
Drawing out speed	m/min	2.0-15.0	2.0-10.8
Positioning control method		Leader mast tilting	Leader mast tilting
Applicable sheet piles		N/A	N/A
Applicable tube piles		ø1000 ø1100 ø1200	ø1300 ø1400 ø1500
Operating system		Wireless radio-control	Wireless radio-control
Moving system		Self travelling	Self travelling
Chuck rotation	degrees	48	55
Weight	kg	28000	50600

### PZ1200

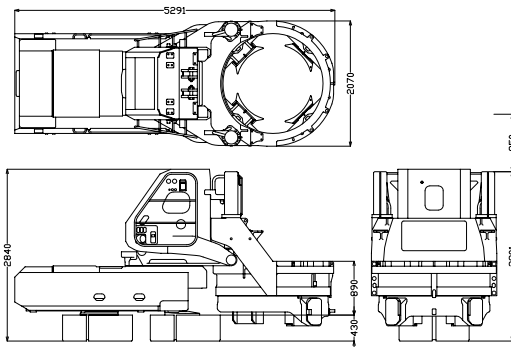

### PZ1500

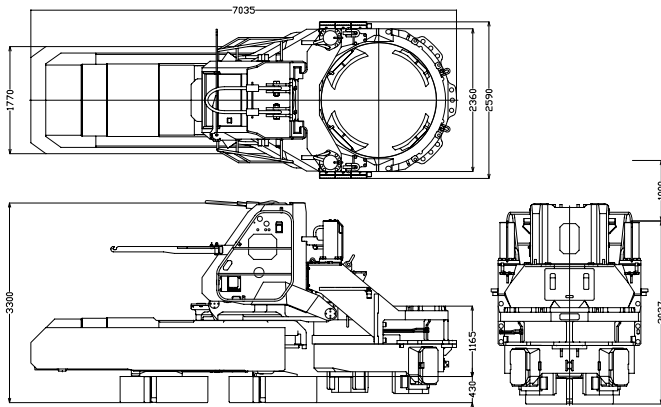

## Hydraulic Power Pack

		KE200C5
Power		Diesel engine
Output rating	kw/min	168/1800 -1
Fuel oil tank	litres	400
Hydraulic oil tank	litres	550
Weight	kg	7150

### Stage IV Engine

The Still Worker power packs comply with stage IV EU regulations which specify emission requirements for all new non-road mobile machinery.

### Bio-oil

The use of ECO friendly Bio hydraulic oil means that any leak or spillage won't cause catastrophic harm to the environment.



All measurements are approximate and are subject to change. Please contact us if you need exact measurements for a specific piece of equipment.





E: [info@w-h.co.uk](mailto:info@w-h.co.uk)  
W: [www.w-h.co.uk](http://www.w-h.co.uk)

Head Office: White House Road | Ipswich | Suffolk | IP1 5NT | T: +44(0)1473 748652  
Northern Depot: Lyncastle Road | Appleton Thorn Trading Estate | Warrington | WA4 4RE | T: +44(0)1925 265358