

Dieseko PVE Hydraulic Piling Vibrators

UK & Ireland Sales Agents

Introduction

Hydraulic vibrators have wide applications in driving and extracting sheet piles, profiles and steel pipes and are also ideally suited to offshore and underwater work, where they can operate to considerable depths. When modified, non-piling applications that the machines can be used for include soil compaction and construction of vertical drains.

Dieseko, specialist Dutch manufacturers of PVE (Piling and Vibro Equipment) vibrators, have concentrated on improving performance and reducing still further unwanted external vibrations from this quiet and intrinsically environment-friendly technology.

Standard units – 14M, 23M, 25M, 27M, 38M, 52M, 105M, 110M and 200M

The range of standard units spans nine models, delivering between 450kN and 4400kN of centrifugal force.

High frequency units – 2307, 1420, 2315 and 2520

High frequency units transmit less vibration to the direct vicinity and are recommended for use in built-up areas. The four models available deliver between 380kN and 1120kN of centrifugal force.

Variable moment units – 2310VM, 2316VM, 2319VM, 24VM, 2332VM, 2335VM, 40VM and 50VM

At the very forefront of developments, Dieseko have now introduced a range of variable moment (VM) units which employ automatic or manually adjustable eccentrics that allow the machine to accelerate to maximum speed before the vibrating action begins. Vibration is also disabled before the machine stops. The benefit is that no low-frequency vibrations are generated at any time during operation, making VM units particularly suitable for use



close to highly sensitive structures or services. The eight VM models deliver between 580kN and 2200kN of centrifugal force.

Power units

PVE diesel hydraulic power units are specifically designed and built for use with PVE vibrators, ensuring optimum performance and efficiency. Features include fault protection of the system, fully adjustable hydraulic pump for perfect vibrator frequency control, noise reduction, and pile clamp operation in idling condition.



Watson & Hillhouse Ltd.,

Whitehouse Road, Ipswich,
Suffolk IP1 5NT England
Tel: +44 (0)1473 748652
Fax: +44 (0)1473 240090
Email: info@w-h.co.uk
Web: www.w-h.co.uk

Technical Data

High Frequency Vibrators with Variable Moment

	2335 VM	50 VM	40 VM	2332 VM	24 VM	2319 VM	2316 VM	2310 VM
Eccentric moment	0-35	0-50	0-40	0-32	0-24	0-19	0-16	0-10
Frequency	2300	2000	2000	2300	2300	2300	2300	2300
Centrifugal force	2000	2200	1750	1900	1400	1100	928	580
Line pull capacity	500	400	400	500	400	300	300	200
Total weight (less clamp)	6400	7000	6200	6000	5800	3100	3000	1900
Vibrating weight	4400	4750	4300	4300	4150	2450	2350	1450
Amplitude	0-16	0-21	0-19	0-15	0-14	0-16	0-14	0-14
Standards hose length	47	47	47	47	32	32	32	32
L x W x H	2300 x 750 x 2350	2600 x 750 x 2550	2600 x 750 x 2550	2300 x 750 x 2350	1960 x 750 x 2480	1600 x 750 x 2050	1600 x 750 x 2050	1260 x 650 x 1570
Power unit	800/1000	800	800	800	500/600	500	480	280

High Frequency Vibrators

	2520	2315	1420	2307
Eccentric moment	25	15	14	6.5
Frequency	2000	2300	2000	2300
Centrifugal force	1120	870	620	380
Line pull capacity	400	300	240	150
Total weight (less clamp)	5150	2800	1900	1400
Vibrating weight	3050	1880	1210	780
Amplitude	16	16	21	17
Standards hose length	32	32	32	32
L x W x H	2400 x 700 x 1950	1700 x 750 x 1600	1400 x 475 x 1450	1350 x 570 x 1400
Power unit	480	360	280	280

Sheet Pile Clamps

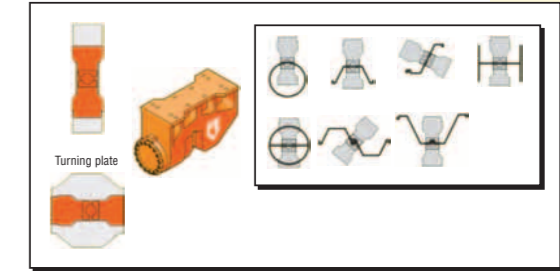

Power Units

	1600	1000	800	600	500	480	360	280
Diesel engine	2 x Volvo	2 x Volvo	Volvo	Volvo	Volvo	Volvo	Volvo	Cummins
Power	1130/1536	784/1066	564/767	440/600	392/533	294/400	234/318	190/260
Oilflow	1600	1000	800	600	500	480	360	280
Work pressure	350	350	350	350	350	350	350	350
Weight	16000	9500	8500	6000	5800	5500	4150	3500
L x W x H	6060 x 2438 x 2670	5000 x 2200 x 2325	4720 x 1800 x 2200	4620 x 1650 x 2100	4250 x 1650 x 2100	4250 x 1650 x 2100	3500 x 1400 x 1750	3000 x 1300 x 1600

Double Clamps

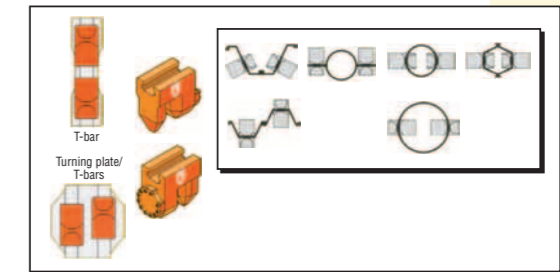

Standard Frequency Vibrators

	200 M	110 M	105 M	52 M	38 M	27 M	25 M	23 M	14 M
Eccentric moment	200	110	105	52	38	27	27	23	14
Frequency	1400	1350	1350	1700	1700	1700	1700	1650	1700
Centrifugal force	4400	2250	2150	1650	1200	870	870	700	450
Line pull capacity	1800	800/1200	800/1200	500	400	350	400	400	240
Total weight (less clamp)	25000	12000/13500	12000/13500	6500	5400	3500	4980	4300	2000
Vibrating weight	19000	7000	7000	4000	3400	2350	2900	2300	1310
Amplitude	21	31	30	26	22	23	19	20	21
Standards hose length	62	47	47	47	32	32	32	32	32
L x W x H	3000 x 1600 x 3350	3230 x 1175 x 2500/3000	3230 x 1175 x 2500/3000	2720 x 720 x 2230	2430 x 700 x 2100	1700 x 850 x 1715	2400 x 700 x 1900	2400 x 550 x 1900	1400 x 475 x 1450
Power unit	1600	1000	800/1000	800	500	480	480	360	280

Ring Vibrators

	38 VMR	32 VMR	20 VMR
Eccentric moment	0-38	0-32	0-20
Frequency	2100	2100	2100
Centrifugal force	1900	1600	1000
Line pull capacity	400	400	250
Down pull capacity	400	400	250
Diameter	610-830	408-610	400-510
Weight	11500	9500	6000
L x W x H	2780 x 1500 x 1320	2600 x 1400 x 1320	2400 x 1175 x 1250

Technical Data Clamps

Sheet Pile Clamps

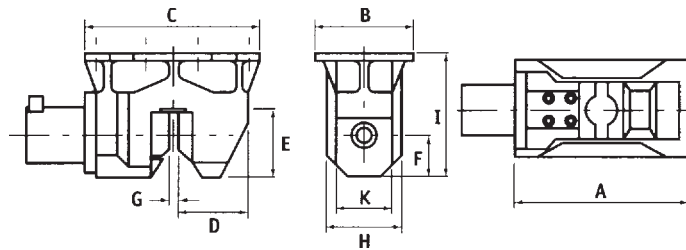

Clamp model	Clamp force kN	Total weight kg	A	B	C	D	E	F	G	H	I	K
55	550	340	740	280	680	237	245	150	33	280	465	145
60	600	310	660	300	416	235	238	150	30	270	465	120
85	850	600	850	300	760	300	295	170	34	330	500	240
110	1100	750	1045	460	835	350	325	200	34	385	590	270
150	1500	1270	1133	460	1000	483	345	205	35	460	705	270
200	2000	2000	1255	460	1040	503	370	280	34	530	920	300

Double Clamps

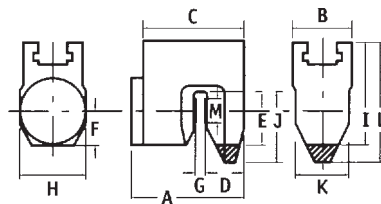

Clamp model	Clamp force kN	Total weight kg	A	B	C	D	E	F	G	H	I	J	K	L	M	min. tube Ø
55	550	310	490	300	405	120	200	135	35	270	450	200	270	450	95	280
80	800	500	590	300	525	196	280	180	55	340	540	370	270	630	105	400
100	1000	690	638	380	573	225	295	195	53	380	555	295	300	555	130	450
125	1250	900	685	400	585	262	300	200	43	400	647	300	372	647	150	540
150	1500	1300	815	420	790	305	330	210	60	420	750	330	330	750	180	610

Pile Clamps

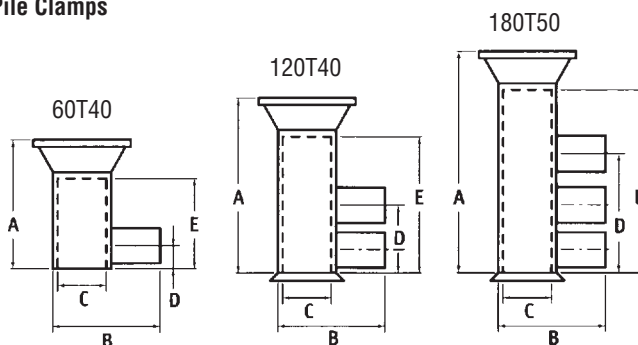

Clamp model	Clamp force kN	Total weight kg	A	B	C	D	E
60T40	600	850	1100	950	410	300	800
120T40	1200	1300	1470	950	410	550	1250
180T50	1800	2700	2750	1050	520	1300	2500



Watson & Hillhouse Ltd.,
 Whitehouse Road, Ipswich,
 Suffolk IP1 5NT England
 Tel: +44 (0)1473 748652
 Fax: +44 (0)1473 240090
 Email: info@w-h.co.uk
 Web: www.w-h.co.uk

Noise Data	Sound Pressure Level Lpa (5m R)	Sound Pressure Level Lpa (10m R)
Power Packs:		
Model 280	71.4 dB(A)	65.4 dB(A)
Model 360	74.4 dB(A)	68.4 dB(A)
Model 450	67.4 dB(A)	61.4 dB(A)
Model 480	77.3 dB(A)	71.3 dB(A)
Model 500	77.3 dB(A)	71.3 dB(A)
Model 600	73.2 dB(A)	67.2 dB(A)
Model 880		
Model 1000	83 dB(A)	77 dB(A)
Vibrators:		
2316VM (sheet pile panel driving)	91 dB(A)	85 dB(A)
25VM (sheet pile panel driving)	89 dB(A)	83 dB(A)
40VM (single tubular pile)	92 dB(A)	86 dB(A)

NB. Noise emissions will vary depending on type of pile being installed i.e. panel of sheet piles or single bearing pile, method of installation, site location and ambient noise.

Cyclical operations will result in an overall reduction of noise (leq).

To calculate the noise level at further distances, reduce the noise level by 6dB(A) each time the distance is doubled.



PVE 2323VM



PVE 2316VM