



AMPHIBIOUS EXCAVATORS



AMPHIBIOUS EXCAVATORS

member of **DIESEKO GROUP**





BELL DREDGING EQUIPMENT

The Dutch are experts in solving and overcoming maritime and civil challenges due to the centuries of struggle and battle to keep the lowlands we live on protected and dry to the ever rising sea level. Bell Dredging Equipment is the solution provider that is specialized in engineering and manufacturing durable dredge equipment that will last in the harsh conditions often faced on- and offshore.

Our field of expertise is (mainly) focussed on Bell amphibious excavators, cutter suction dredgers, heavy-duty dredge pumps, special dredge tools and process and production instrumentation. The Bell Dredging Equipment network is rapidly expanding globally with over 45 dealerships and service hubs. Covering all the continents with our equipment portfolio and know how is a key objective for a long-term sustainable relationship with our customers.



To extend the support to our customers worldwide, Bell dredging Equipment now raised the bar even higher by adding a complete rental fleet of heavy duty dredge pumps and amphibious excavators. The Bell rental fleet can be mobilized and dispatched all over the world accompanied with our dedicated trained Bell operators.

The Bell dredging team for after-sales services & support are available 24/7 to assist and support all business partners in achieving the maximum efficiency in all projects.

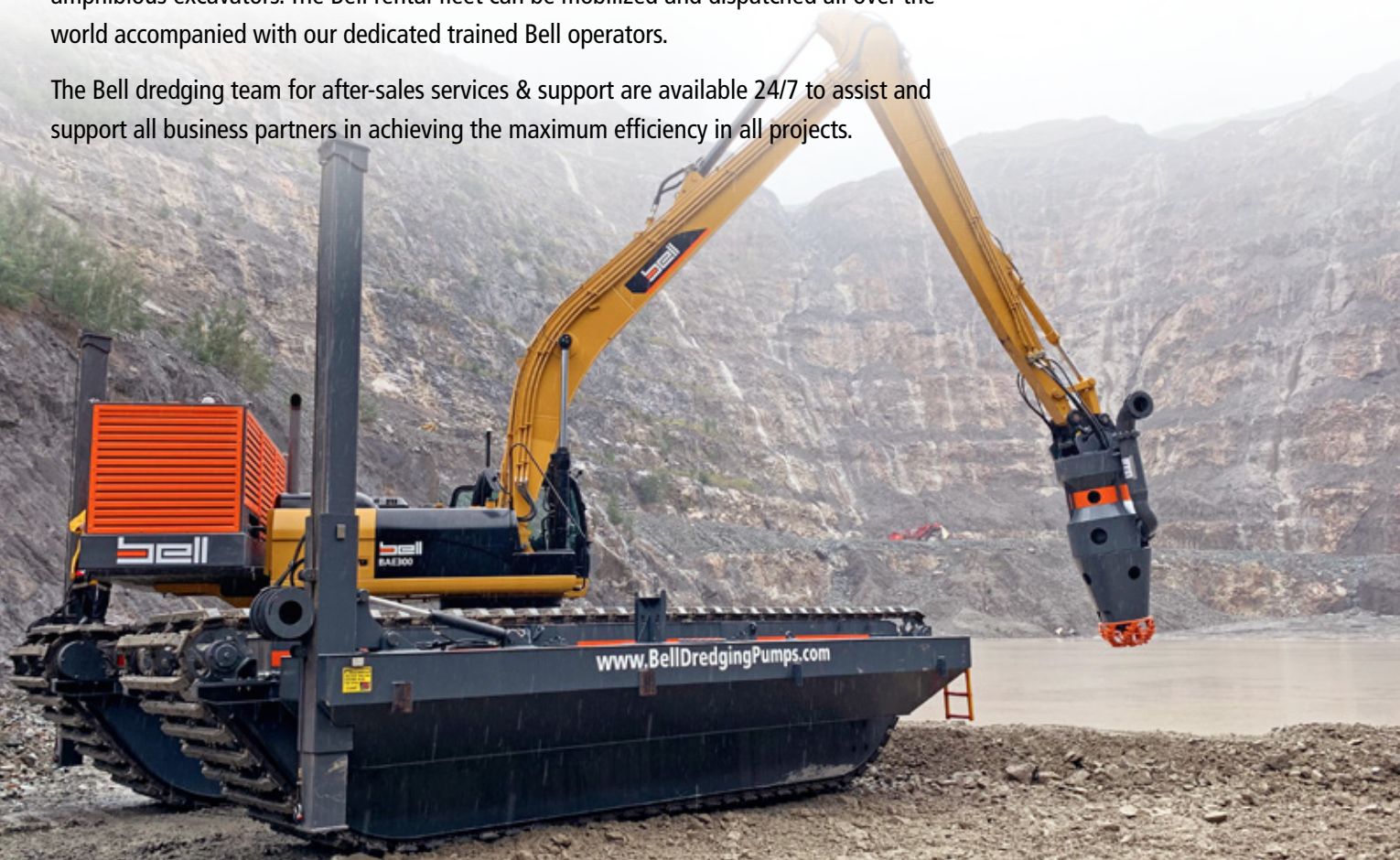



OVERVIEW





ENGINEERING

Product design is accomplished by utilizing the latest CAD software, simulated via advanced Finite Element Analysis (FEA) tools, ensuring optimum design integrity. BELL Engineering is committed to be leading in innovation and quality manufacturing to meet all our customer's needs. Our goal has been and will be to further capitalize on our over 30 years of experience as a contractor in the construction and dredging industry prior to venturing into attachment design and manufacturing. We strive to be your supplier of choice with best in class quality, workmanship and outstanding customer service. We believe we are in the best position to produce functionally superior and practical attachments that customers desire.



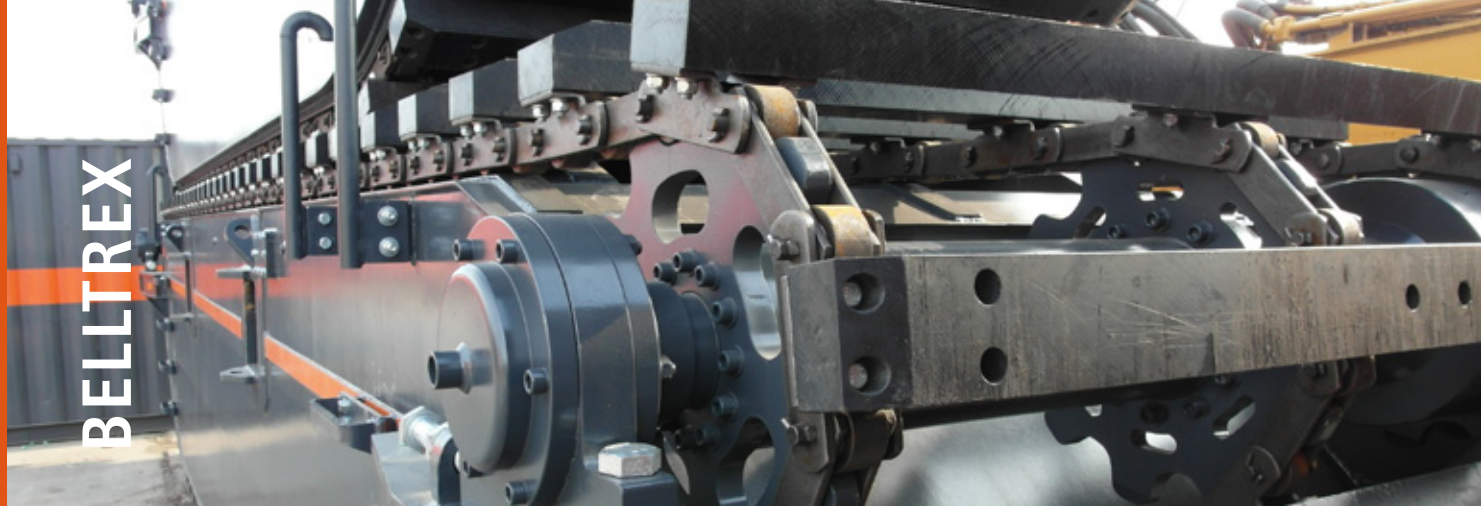

A BELLTREX is an Amphibious Excavator that is designed for working in harsh environments like water bogged soft grounds, swampy lands and shallow waterways. The excavator is fitted with special pontoons. The BELLTREX can operate in shallow water as well as in fully floating condition. Several options can be added such as thrusters, side pontoons and spud legs.

BELLTREX is most effective when it works in areas where the water depth is less than 1.8 meter. For water depth more than 1.8 meter, additional side pontoons with spud legs are required. Because you will never be sure of the water depth of your workplace, fitting the BELLTREX with side pontoons will ensure operator safety and workability.

Diagram A

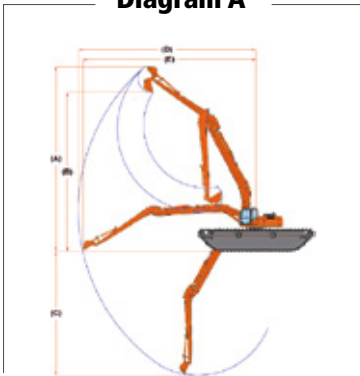
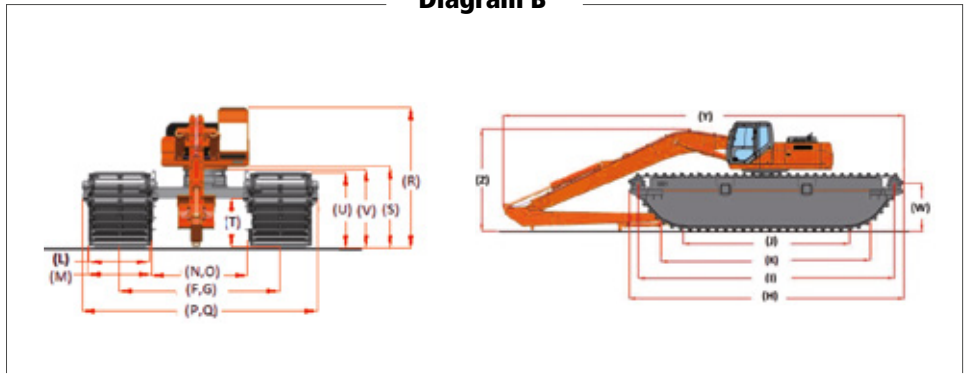

Diagram B



PRINCIPAL SPECIFICATIONS & DIMENSION									
Item	Description	Unit	Bell Amphibious Undercarriage Models						
			BAU35	BAU50	BAU80	BAU120	BAU200	BAU300	BAU400
			Class 3-4 ton Excavator	Class 5-6 ton Excavator	Class 7-9 ton Excavator	Class 10-14 ton Excavator	Class 20-24 ton Excavator	Class 28-36 ton Excavator	Class 40-45 ton Excavator
1	Total Weight (Hollow/UMPE trackshoe)	Kg	10500	12500/11750	16000/15000	24500/22750	32000/30000	45000/43000	54000
2	Float Capacity	m ³	12,5	15	21	30	40	60	65,6
3	Total Weight/Float Capacity (Max)	Ton/m ³	0,84	0,83	0,76	0,82	0,80	0,75	0,82
4	Maximum Torque Motor	Kgf-m	1250	1250	1250	1850	2616	3480	3800
5	Ground Pressure (Soft Ground)	Kg/cm ²	0,178	0,10	0,12	0,12	0,13	0,15	0,12
6	Travel Speed (HI)	km/h	4,2	4,2	4,2	4,2	3,6	3,2	3,2
	Travel Speed (LO)	km/h	2,3	2,2	2,2	2,3	2,3	1,8	1,8
7	Maximum Gradient	Deg	30	30	30	30	30	30	35
Work Equipment									
8	Boom Lenth	mm	3850	3850	4600	7250	7750	9100	10600
9	Arm Lenth	mm	1640	1640	2600	5125	5150	6200	5000
10	Bucket Capacity	m ³	0,15	0,16	0,3	0,4	0,5	0,9	1,4
Working Range									
A	A. Max. Digging Height	mm	6900	6900	9570	13720	14360	17035	15310
	B. Max. Dumping Height	mm	5185	5185	7440	12320	12260	14545	12000
	C. Max. Digging Depth	mm	2845	2845	4980	7930	8250	10150	11240
	D Max. Digging Reach	mm	6220	6220	9000	12500	13500	16000	17000
	E. Max. Digging Reach on Ground	mm	5805	5805	8780	12280	13250	15725	15330
Dimensions									
B	F. Track Gauge (Fully Retracted)	mm	1970	1970	2200	2760	2760	3805	4680
	G. Track Gauge (Fully Extended)	mm	2790	2790	3020	4020	4020	4405	
	H. Track Lenth	mm	6575	6583	7710	9210	9520	10670	10640
	I. Distance Between Idler	mm	5790	5790	6910	8433	8790	9802	9900
	J. Track Lenth On Hard Ground	mm	3367	3367	4275	5710	5700	6650	7100
	K. Track Lenth On Soft Ground	mm	5790	5810	6825	7150	7735	8310	10145
	L. Width Track Shoe	mm	1000	1040	1270	1590	1590	1775	2000
	M. Width Float	mm	1070	1070	1300	1620	1620	1807	2025
	N. Distance Between Pontoons (Fully Retracted)	mm	900	900	900	1170	1170	2030	2680
	O. Distance Between Pontoon (Fully Extended)	mm	1750	1720	1720	2440	2440	2630	
	P. Overall Machine Width (Fully Retracted)	mm	3140	3300	3760	4660	4660	5950	7200
	Q. Overall Machine Width (Fully Extended)	mm	3770	4120	4580	5930	5930	6550	
	R. Overall Machine Height (Cabin)	mm	3490	3500	3500	3685	4050	4435	4450
	S. Ground Clearance (Counterweight)	mm	1655	1655	1655	1755	2120	2520	2460
	T. Min. Ground Clearance	mm	990	990	990	1040	1250	1610	1640
	U. Shoe Setting Height	mm	1520	1550	1550	1610	1920	2295	2220
	V. Crawler Height	mm	1585	1580	1580	1700	2035	2370	2355
	W. Water Line Level	mm	1125	1130	1150	1185	1510	1880	1850
	X. Min. Swing Radius (Counterweight)	mm	950	1060	1576	2140	2750	3500	3605
	Y. Overall Length	mm	7010	7010	7100	12290	13100	14900	17180
Z. Height of Boom (Transportation)	mm	2500	2700	2700	2850	3450	4000	5240	

* Dimensions are for references only. It might differ and depend on the brand or model of the excavator

** Specifications are subject to change without prior notice



NEW: BELLTREX ERN AMPHIBIOUS UNDERCARRIAGES

Our newly developed ERN undercarriages are Extendable, Retractable, Narrow undercarriages.

The pontoons are longer, less wide, and are always equipped with hydraulic cylinders to extend and retract the pontoons.

Due to this feature, an amphibious excavator on this type of undercarriage can be transported as a complete machine instead of taking it apart first. The undercarriages that can be designed in the ERN version are the BAU120 and the BAU200 undercarriage. Dimensions of the BAU200 ERN amphibious undercarriage are shown on the right.

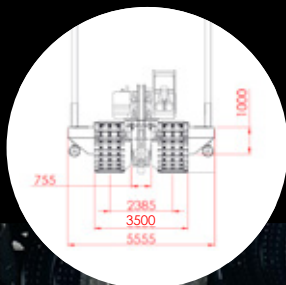

SPUD LEGS

The side pontoons are attached to the side of the undercarriage and can be equipped with either one or two spud legs each. Tilting and pulling the legs up or down can be controlled from within the cabin.

SWAP SYSTEM

Switching between your standard undercarriage and amphibious undercarriage will no longer be a time consuming job when you have a Bell Swap System.

We can modify the standard undercarriage of every excavator so that it can be swapped easily with your amphibious one. Together with quick couplings on the hydraulic hoses, swapping should not take longer than 30 minutes.

THRUSTERS

The Bell Thruster is a hydraulically driven thruster which is connected to the undercarriage and can be controlled from within the cabin. If the jobsite is remote or you need to get there fast, Bell thrusters are essential. The thrusters ensure you can maneuver the amphibious excavator in strong currents and across big bodies of water.

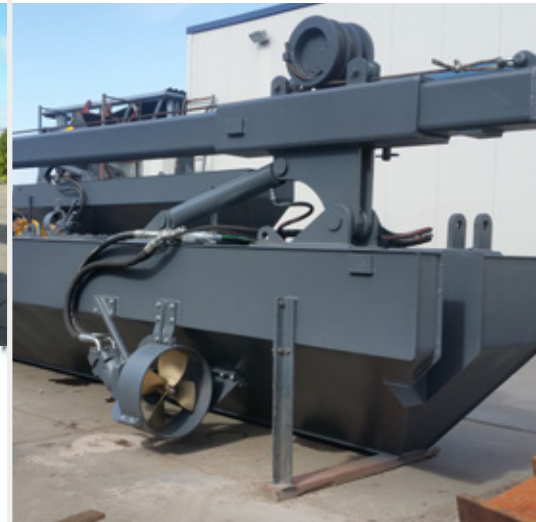
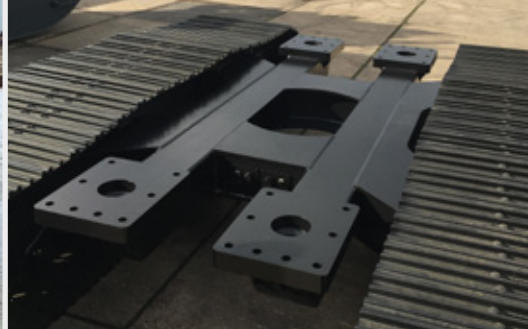



BELL 300 AMPHIBIOUS SELF-PROPELLED DRILLING MACHINE

Hydraulic power pack general data

Engine model	John Deere 4045 HFG 82
Engine power	115 kW
Displacement	4,5 L
Total weight	2000 kg
Height	8 m
Length	11,5 m
Width	8,6 m

Platform

Total weight	5760 kg
Height	145 mm
Length	10,5 m
Width	6,5 m



BELL AMPHIBIOUS EXCAVATOR 400 WITH HYDRAULIC PILING HAMMER

Configuration:

- 45 ton amphibious undercarriage
- PVE 3NL piling hammer
- Four 9-meter long spudlegs





SPARES AND SERVICES

After sales department:

- Components with short delivery time
- Complete package of spare parts
- Registration of components
- Advice and support
- Dedicated team involved from order to shipment

Bell Field Service:

- Warranty and after sales services
- Training courses (in house and on site)
- Technical check-ups
- Service in remote areas
- Experienced operators





member of **DIESEKO GROUP**

MORE INFORMATION:
BELLDREDGING.COM

Bell Dredging Pumps B.V. | Winkelerzand 1a | 1731 LR Winkel, the Netherlands | Telephone: +31(0)224-855 340
www.BellDredging.com | info@BellDredging.com | VAT: NL8522.96.964 | COC: 56 77 52 45

Dealer:



092021-ENG