

Specifications :

ICE 12RF

Eccentric moment	0-12 kgm	Clamps:	
Max. centrifugal force	0-700 kN	Sheet pile clamp	100TU
Max. frequency	2300 rpm	Transport weight per piece	490 kg
Max. amplitude excl. 100TU	17 mm	Double clamps	55TC
Max. amplitude incl. 100TU	12,4 mm	Transport weight per piece	310 kg
Max. static line-pull	250 kN		
Max. pull-down	120 kN		
Max. operating pressure	350 bar	Powerpack:	
Max. oil flow	261 l/min	Model	300 series
Max. hydraulic power	152/207 kW/HP		
Forced lubrication	yes		
Dynamic weight excl. 100TU	1450 kg	Hose set:	
Dynamic weight incl. 100TU	1940 kg	Length	30 m
Total weight excl. 100TU & hoses	2396 kg	Transport weight (±)	465 kg

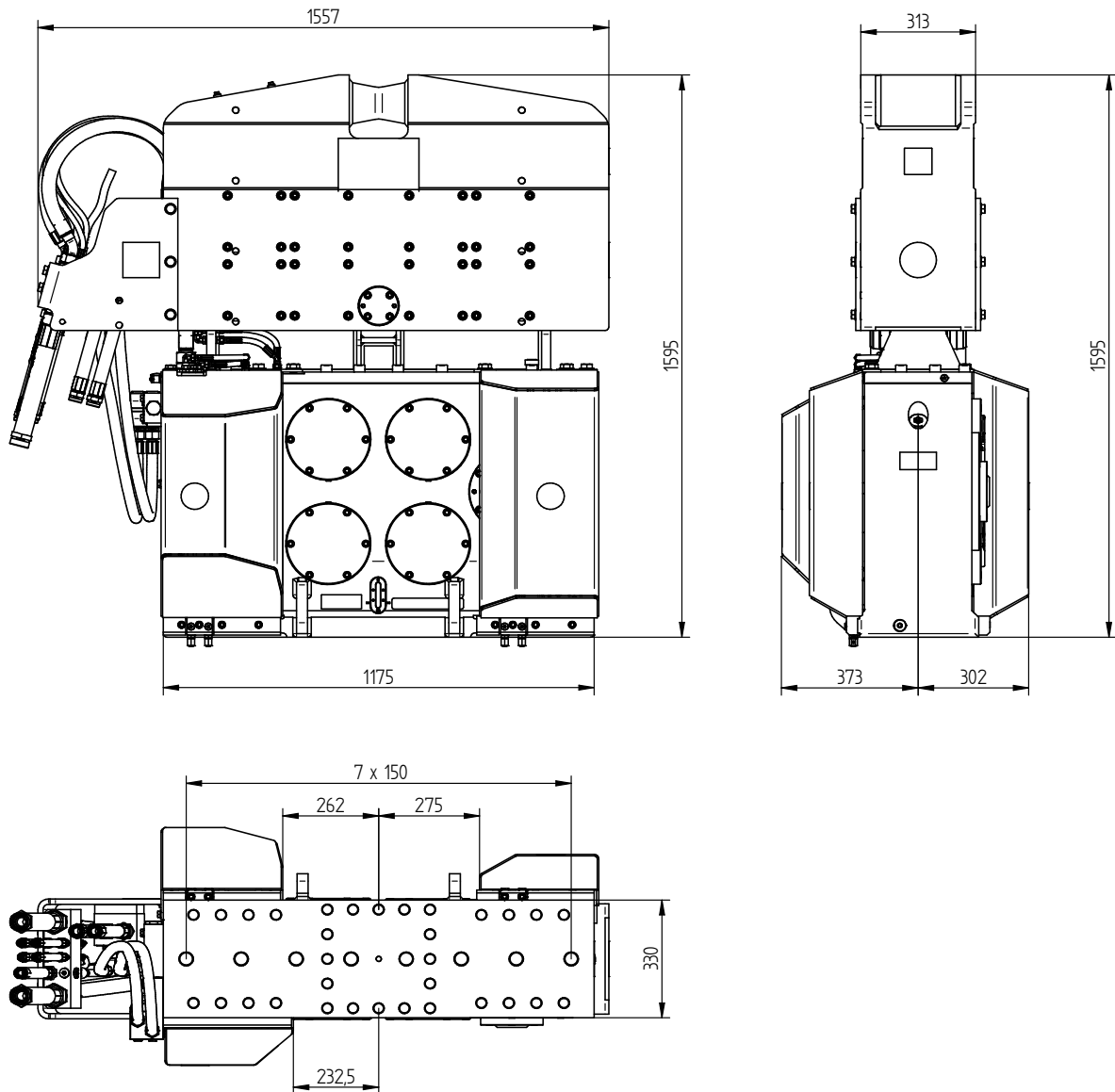

Technische Daten :

ICE 12RF

Statisches Moment	0-12 kgm	Klemmzange:	
Max. Fliehkraft	0-700 kN	Universalzange	100TU
Max. Drehzahl	2300 rpm	Transportgew. pro Stück	490 kg
Max. Amplitude ohne 100TU	17 mm	Rohrklemmzange	55TC
Max. Amplitude mit 100TU	12,4 mm	Transportgew. pro Stück	310 kg
Max. Statische Zugkraft	250 kN		
Max. Vorspannung	120 kN		
Max. Betriebsdruck	350 bar	Aggregat:	
Max. Fördermenge	261 l/min	Modell	300 series
Max. hydraulische Leistung	152/207 kW/PS		
Zwangsschmierung	ja		
Dyn. Gewicht ohne 100TU	1450 kg	Schlauchsatz:	
Dyn. Gewicht mit 100TU	1940 kg	Länge	30 m
Gesamtgew. ohne 100TU & Schläuche	2396 kg	Transportgewicht (±)	465 kg

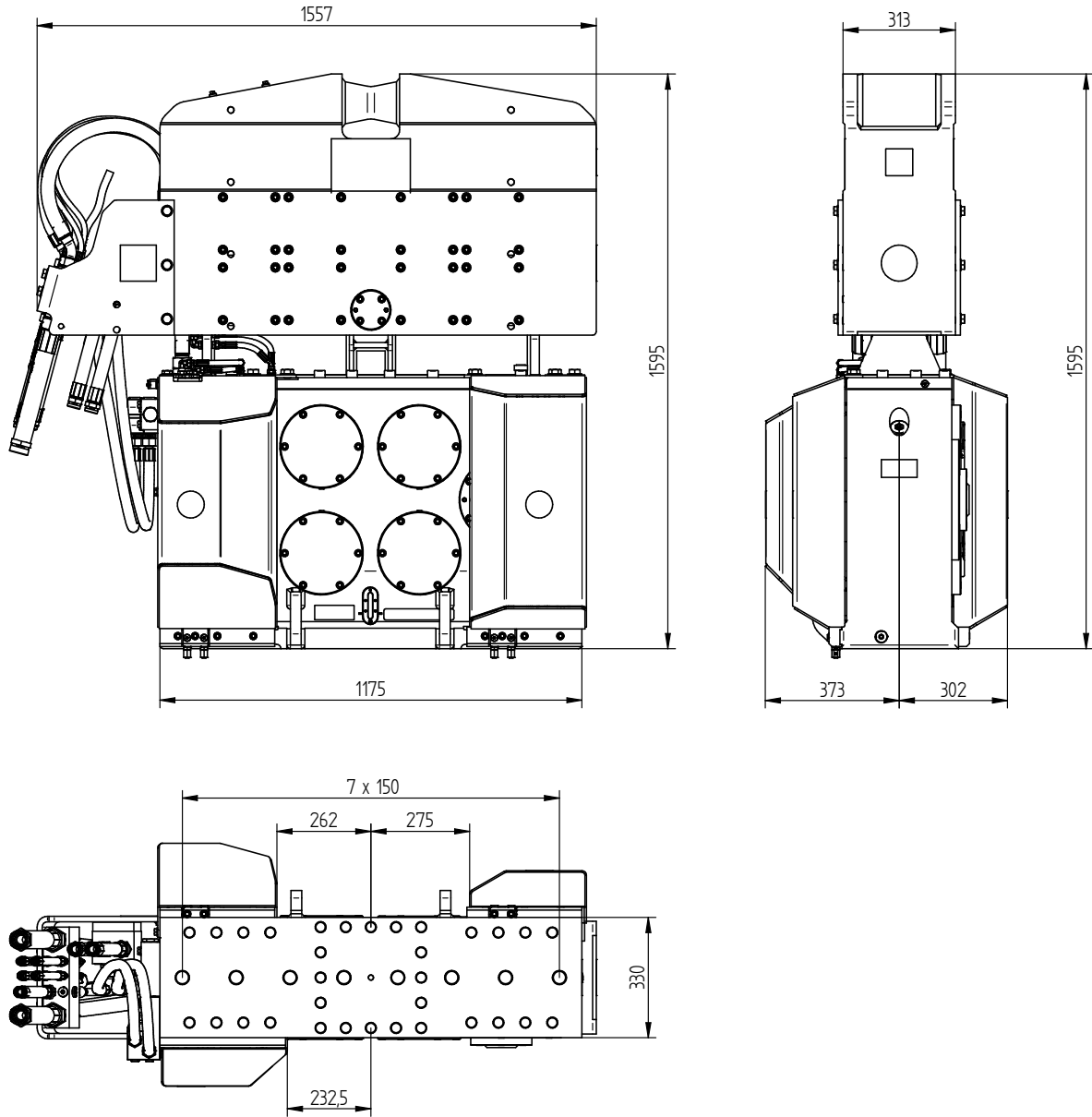

Spécifications

ICE 12RF

Moment excentrique	0-12 kgm	Pinces:	
Max. force centrifuge	0-700 kN	Pince palplanche	100TU
Max. fréquence	2300 rpm	Poids de transport par pièce	490 kg
Max. amplitude sans 100TU	17 mm	Pince tube	55TC
Max. amplitude avec 100TU	12,4 mm	Poids de transport par pièce	310 kg
Force de traction statique	250 kN		
Force maximale d'appui	120 kN		
Pression de travail max.	350 bar	Groupe hydraulique:	
Débit d'huile max.	261 l/min	Modèle	300 series
Puissance hydraulique max.	152/207 kW/ch		
Huile lubrifiante	oui		
Poids dynamique sans 100TU	1450 kg	Jeu de tuyau:	
Poids dynamique avec 100TU	1940 kg	Longueur	30 m
Poids total sans 100TU & tuyaux	2396 kg	Poids de transport (±)	465 kg

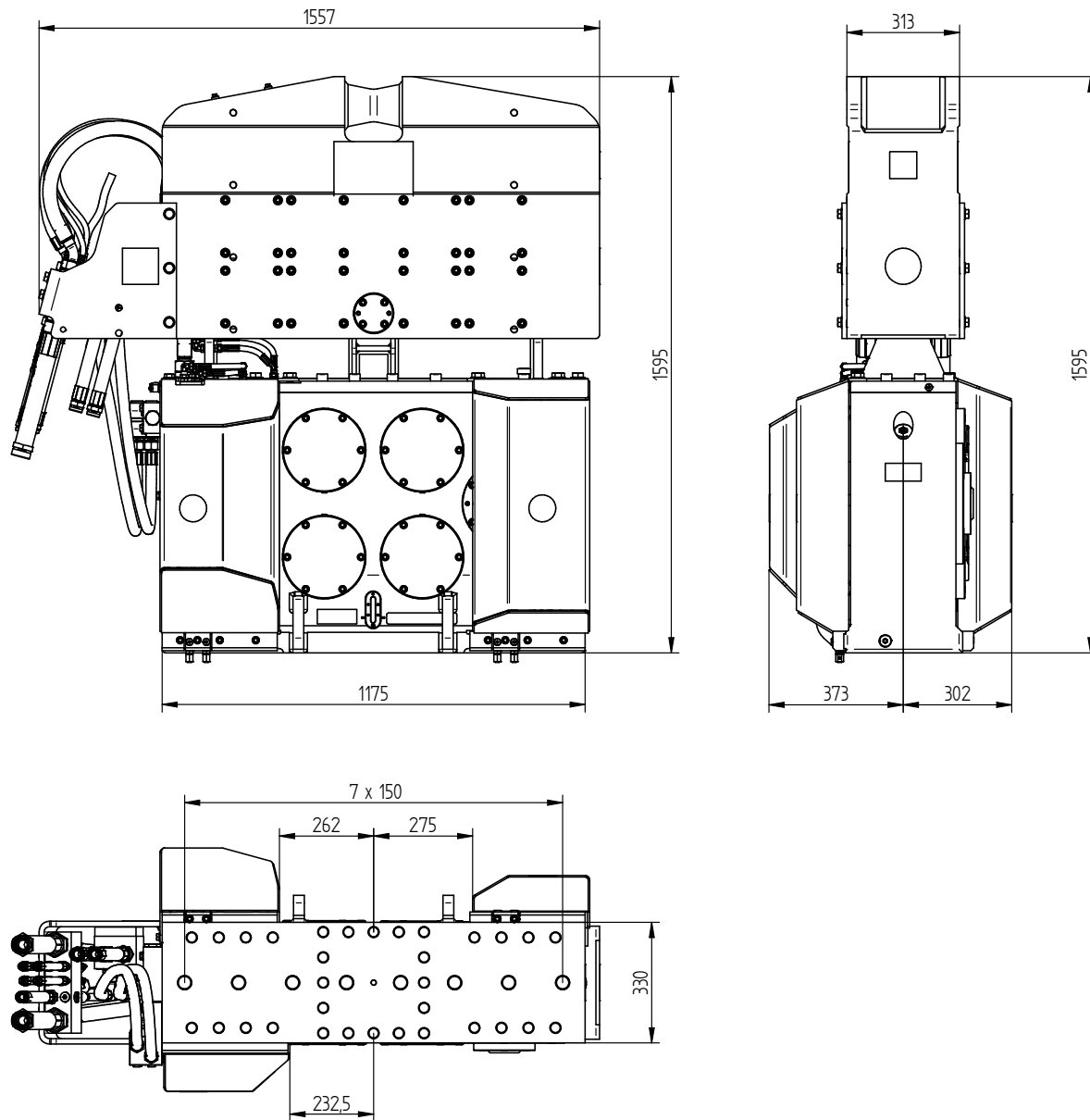

Specificaties

ICE 12RF

Excentrisch moment	0-12 kgm	Klemmen:	
Max. centrifugaalkracht	0-700 kN	Damwandklem	100TU
Max. toerental	2300 rpm	Transportgewicht per klem	490 kg
Max. amplitude excl. 100TU	17 mm	Pijpenklem	55TC
Max. amplitude incl. 100TU	12,4 mm	Transportgewicht per klem	310 kg
Max. statische trekkracht	250 kN		
Max. voorspanning	120 kN		
Max. werkdruk	350 bar	Aggregaat:	
Max. oliedoorstroming	261 l/min	Model	300 series
Max. hydraulisch vermogen	152/207 kW/PK		
Geforceerde smering	ja		
Dynamisch gewicht excl. 100TU	1450 kg	Slangenset:	
Dynamisch gewicht incl. 100TU	1940 kg	Lengte	30 m
Totaalgewicht excl. 100TU & slangen	2396 kg	Transportgewicht (±)	465 kg

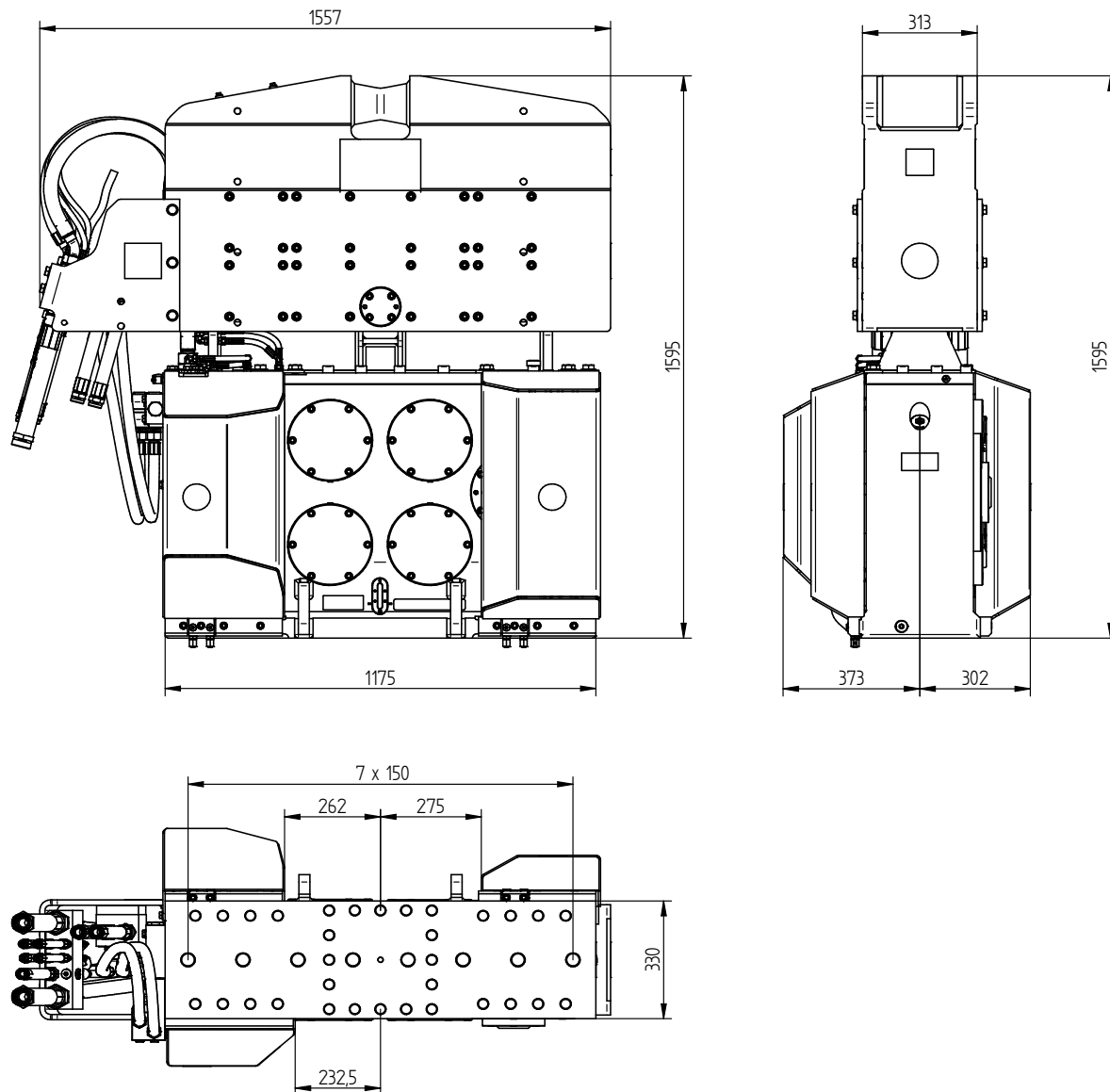

Especificaciones		ICE 12RF	
Momento excéntrico	0-12 kgm	Abrazadera:	
Fuerza centrífuga máxima	0-700 kN	Hoja abrazadera pila	100TU
Frecuencia máxima	2300 rpm	Peso de transporte por pieza	490 kg
Amplitud máxima excluyendo 100TU	17 mm	Abrazadera de tubo	55TC
Amplitud máxima incluyendo 100TU	12,4 mm	Peso de transporte por pieza	310 kg
Estático tracción máxima	250 kN		
Compresión máxima	120 kN		
Presión máxima de trabajo	350 bar	Unidad de potencia:	
Flujo de aceite máximo	261 l/min	Modelo	300 series
Máxima potencia hidráulica	152/207 kW/HP		
Lubricación forzada	si		
Peso dinámico excluyendo 100TU	1450 kg	Conjunto de manguera:	
Peso dinámico incluyendo 100TU	1940 kg	Longitud	30 m
Peso total excluyendo 100TU & mangueras	2396 kg	Peso de transporte (±)	465 kg

Dimensions in inches

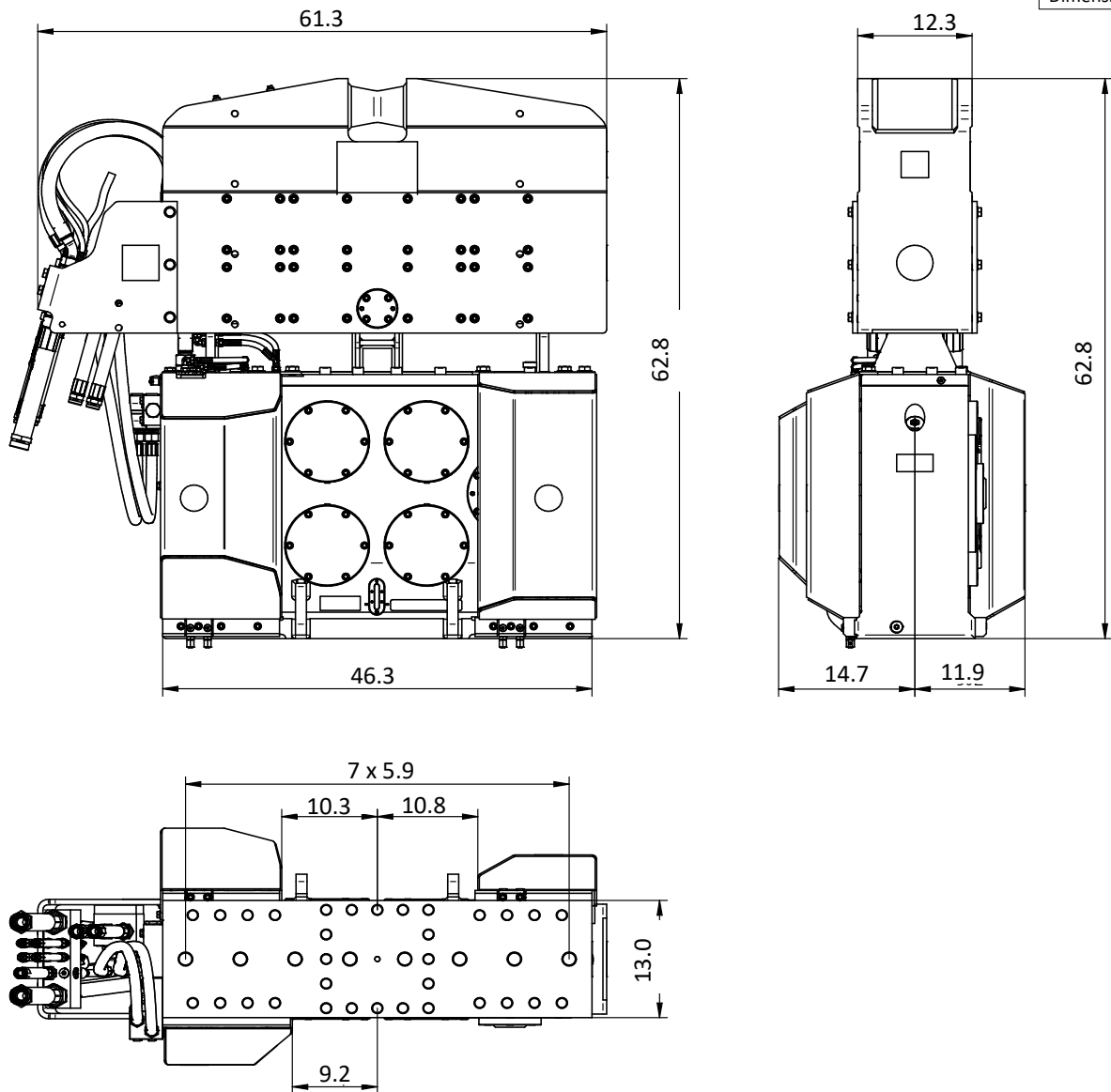

Specifications

ICE 12RF

Eccentric moment	0-1,042 in-lbs	Clamps:	
Max. centrifugal force	0-79 ton	Sheet pile clamp	100TU
Max. frequency	2,300 rpm	Transport weight per piece	1,080 lbs
Max. amplitude excluding 100TU	0.67 in	Double clamps	55TC
Max. amplitude including 100TU	0.49 in	Transport weight per piece	683 lbs
Max. static line-pull	25 ton		
Max. pull-down	12 ton		
Max. operating pressure	5,076 psi	Powerpack:	
Max. oil flow	69 gal/min	Model	300 series
Max. hydraulic power	152/207 kW/HP		
Forced lubrication	yes		
Dynamic weight excluding 100TU	3,197 lbs	Hose set:	
Dynamic weight including 100TU	4,277 lbs	Length	98 ft
Total weight excluding 100TU & hoses	5,282 lbs	Transport weight (±)	1,025 lbs

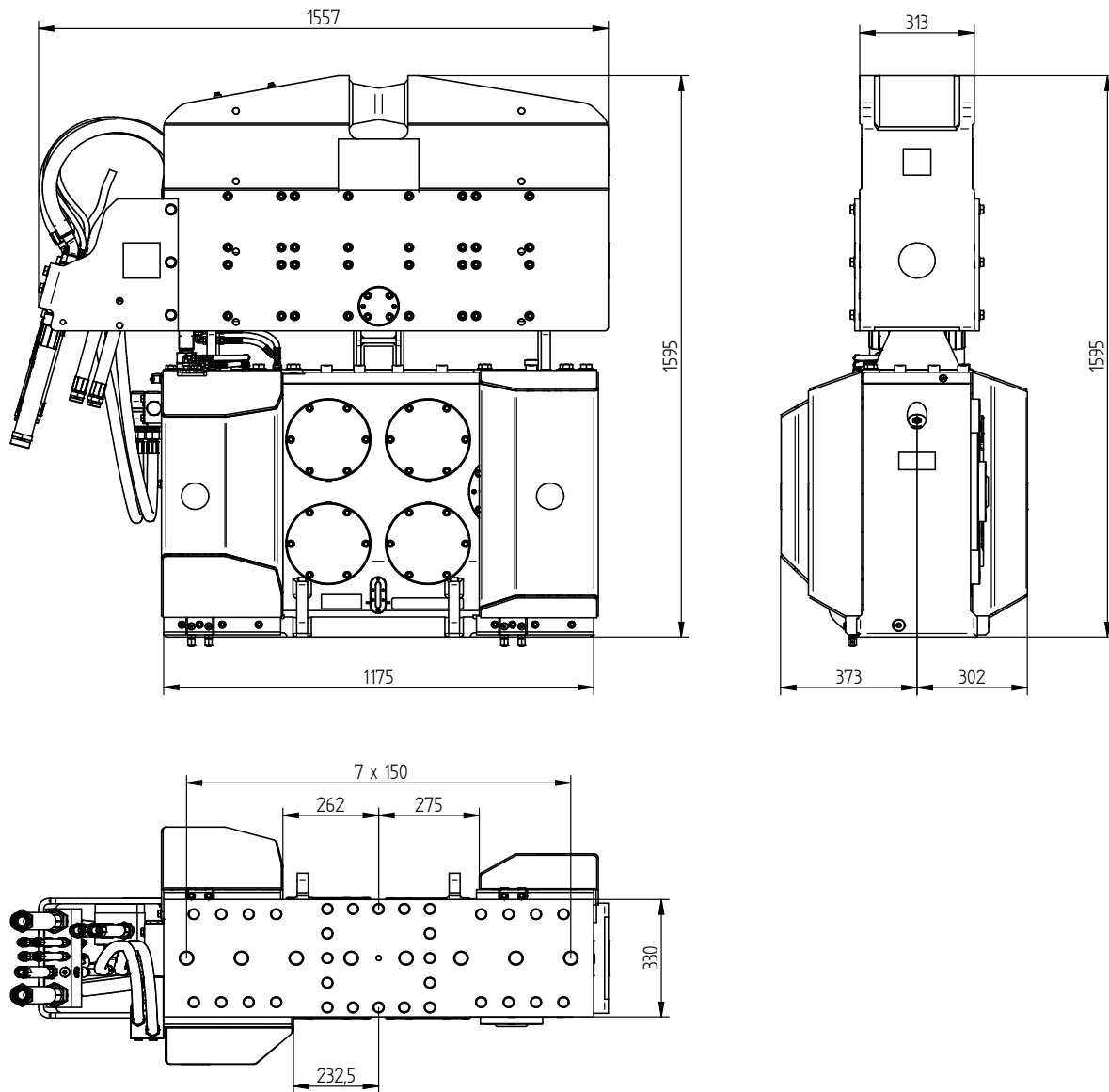

Specificatii :

ICE 12RF

Moment excentric	0-12 kgm	menghira:	
Forta centrifuga maxima	0-700 kN	menghina pentru palplanse	100TU
Frecventa maxima	2300 rpm	Greutatea de transport pp.	490 kg
Amplitudine maxima exclusiva. 100TU	17 mm	menghina dubla	55TC
Amplitudine maxima inclusivă. 100TU	12,4 mm	Greutatea de transport pp.	310 kg
Tractiune maxima statica	250 kN		
Trage în jos maxima	120 kN		
Presiune maxima de lucru	350 bar	generatoare:	
Debit maxim de ulei	261 l/min	Model	300 series
Puterea hidraulică maxima	152/207 kW/HP		
Lubrifiere fortata	da		
Greutatea dinamica exclusiva. 100TU	1450 kg	Tip de furtun:	
Greutatea dinamica inclusivă. 100TU	1940 kg	Lungimea	30 m
Greutatea totala fara. 100TU si furtun	2396 kg	Greutatea de transport (±)	465 kg