

Specifications :

ICE 20RF

Eccentric moment	0-19 kgm	Clamps:	
Max. centrifugal force	0-1100 kN	Sheet pile clamp	130TU
Max. frequency	2300 rpm	Transport weight per piece	610 kg
Max. amplitude excl. 130TU	15 mm	Double clamps	81TC
Max. amplitude incl. 130TU	12 mm	Transport weight per piece	480 kg
Max. static line-pull	240 kN		
Max. pull-down	120 kN		
Max. operating pressure	350 bar	Powerpack:	
Max. oil flow	498 l/min	Model	500 series
Max. hydraulic power	291/396 kW/HP		
Forced lubrication	yes		
Dynamic weight excl. 130TU	2550 kg	Hose set:	
Dynamic weight incl. 130TU	3160 kg	Length	30 m
Total weight excl. 130TU & hoses	3650 kg	Transport weight (±)	615 kg

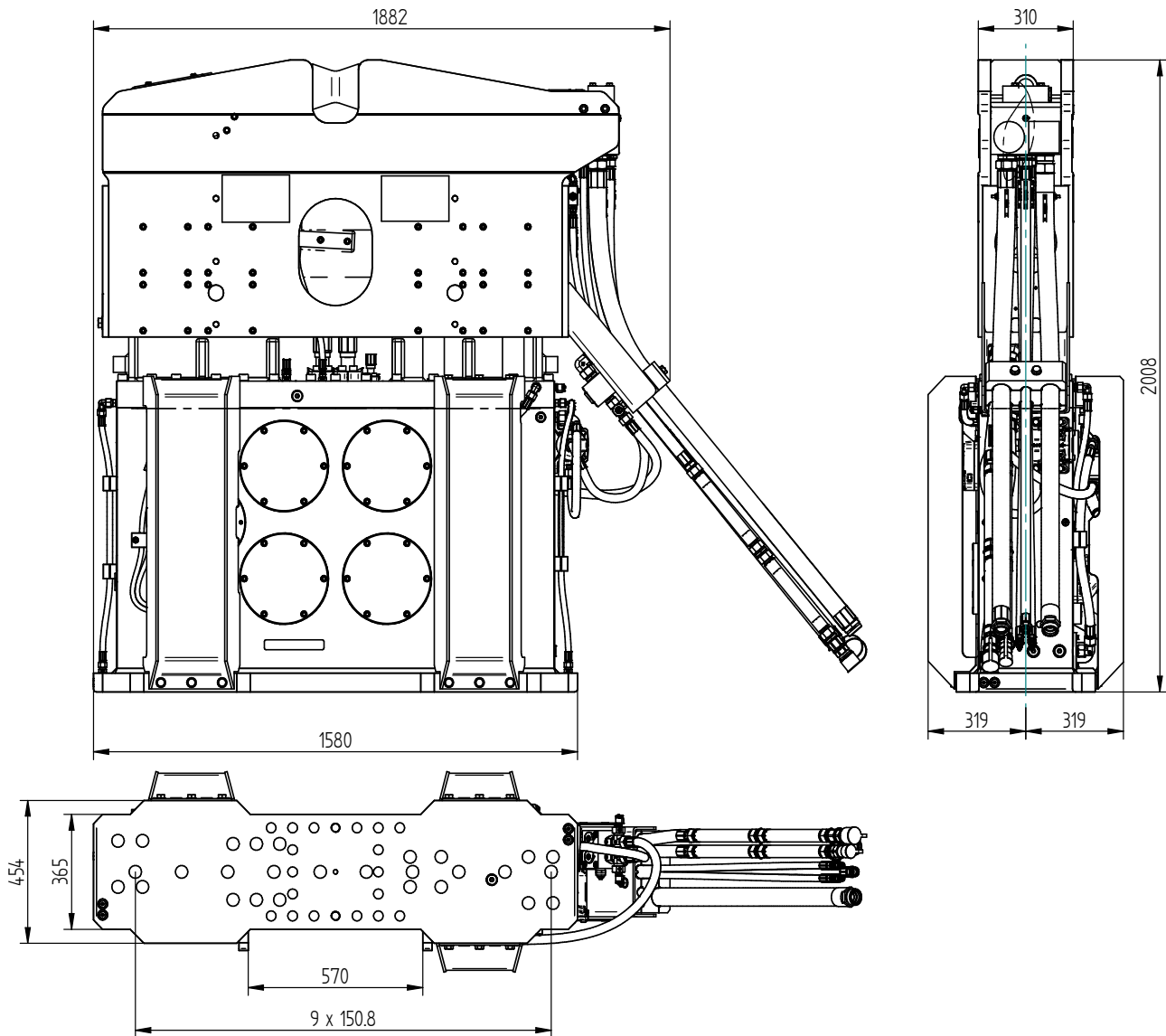

Technische Daten :

ICE 20RF

Statisches Moment	0-19 kgm	Klemmzange:	
Max. Fliehkraft	0-1100 kN	Universalzange	130TU
Max. Drehzahl	2300 rpm	Transportgew. pro Stück	610 kg
Max. Amplitude ohne 130TU	15 mm	Rohrklemmzange	81TC
Max. Amplitude mit 130TU	12 mm	Transportgew. pro Stück	480 kg
Max. Statische Zugkraft	240 kN		
Max. Vorspannung	120 kN		
Max. Betriebsdruck	350 bar	Aggregat:	
Max. Fördermenge	498 l/min	Modell	500 series
Max. hydraulische Leistung	291/396 kW/PS		
Zwangsschmierung	ja		
Dyn. Gewicht ohne 130TU	2550 kg	Schlauchsatz:	
Dyn. Gewicht mit 130TU	3160 kg	Länge	30 m
Gesamtgew. ohne 130TU & Schläuche	3650 kg	Transportgewicht (±)	615 kg

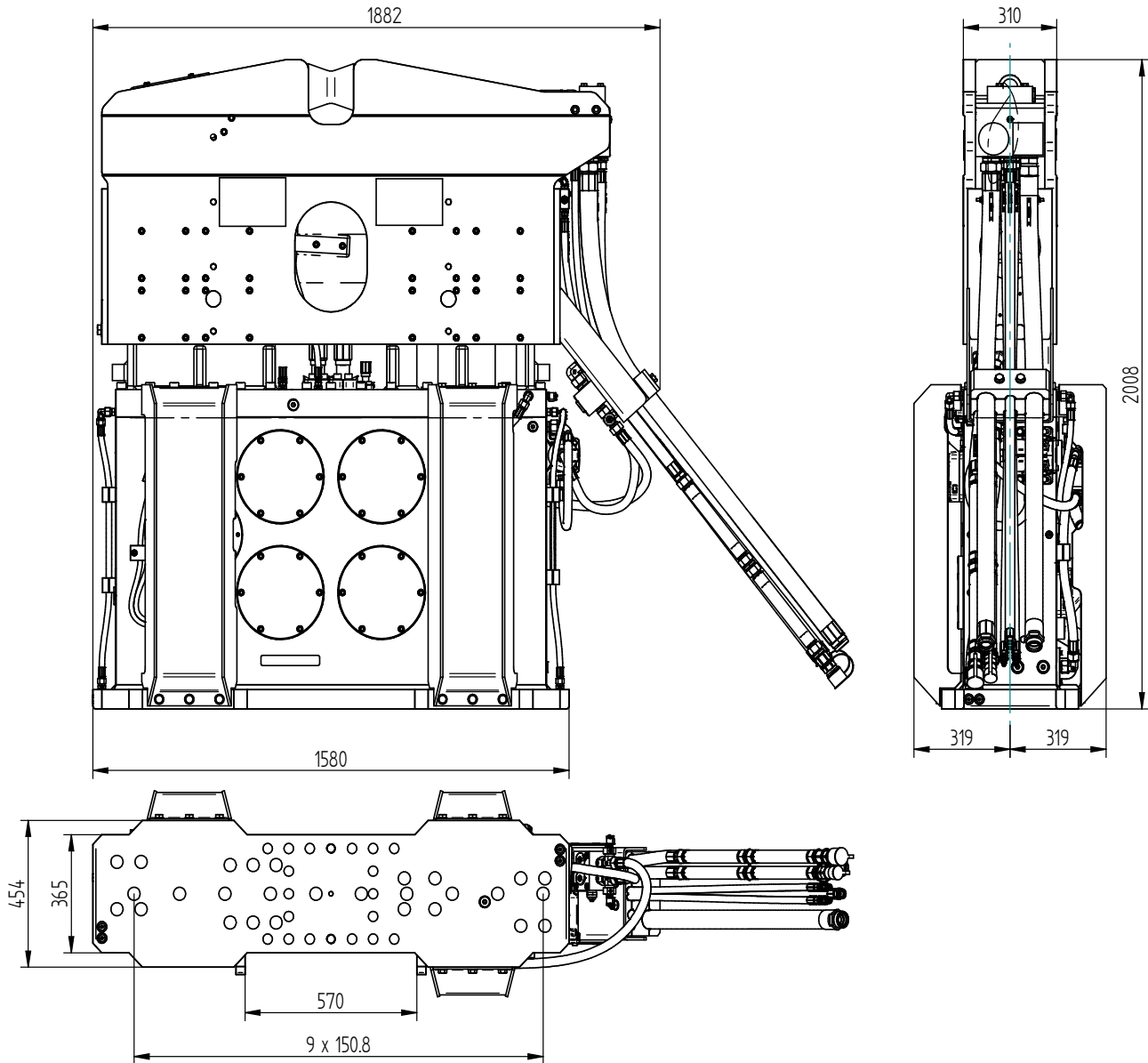

Spécifications

ICE 20RF

Moment excentrique	0-19 kgm	Pincés:	
Max. force centrifuge	0-1100 kN	Pince palplanche	130TU
Max. fréquence	2300 rpm	Poids de transport par pièce	610 kg
Max. amplitude sans 130TU	15 mm	Pince tube	81TC
Max. amplitude avec 130TU	12 mm	Poids de transport par pièce	480 kg
Force de traction statique	240 kN		
Force maximale d'appui	120 kN		
Pression de travail max.	350 bar	Groupe hydraulique:	
Débit d'huile max.	498 l/min	Modèle	500 series
Puissance hydraulique max.	291/396 kW/ch		
Huile lubrifiante	oui		
Poids dynamique sans 130TU	2550 kg	Jeu de tuyau:	
Poids dynamique avec 130TU	3160 kg	Longueur	30 m
Poids total sans 130TU & tuyaux	3650 kg	Poids de transport (±)	615 kg

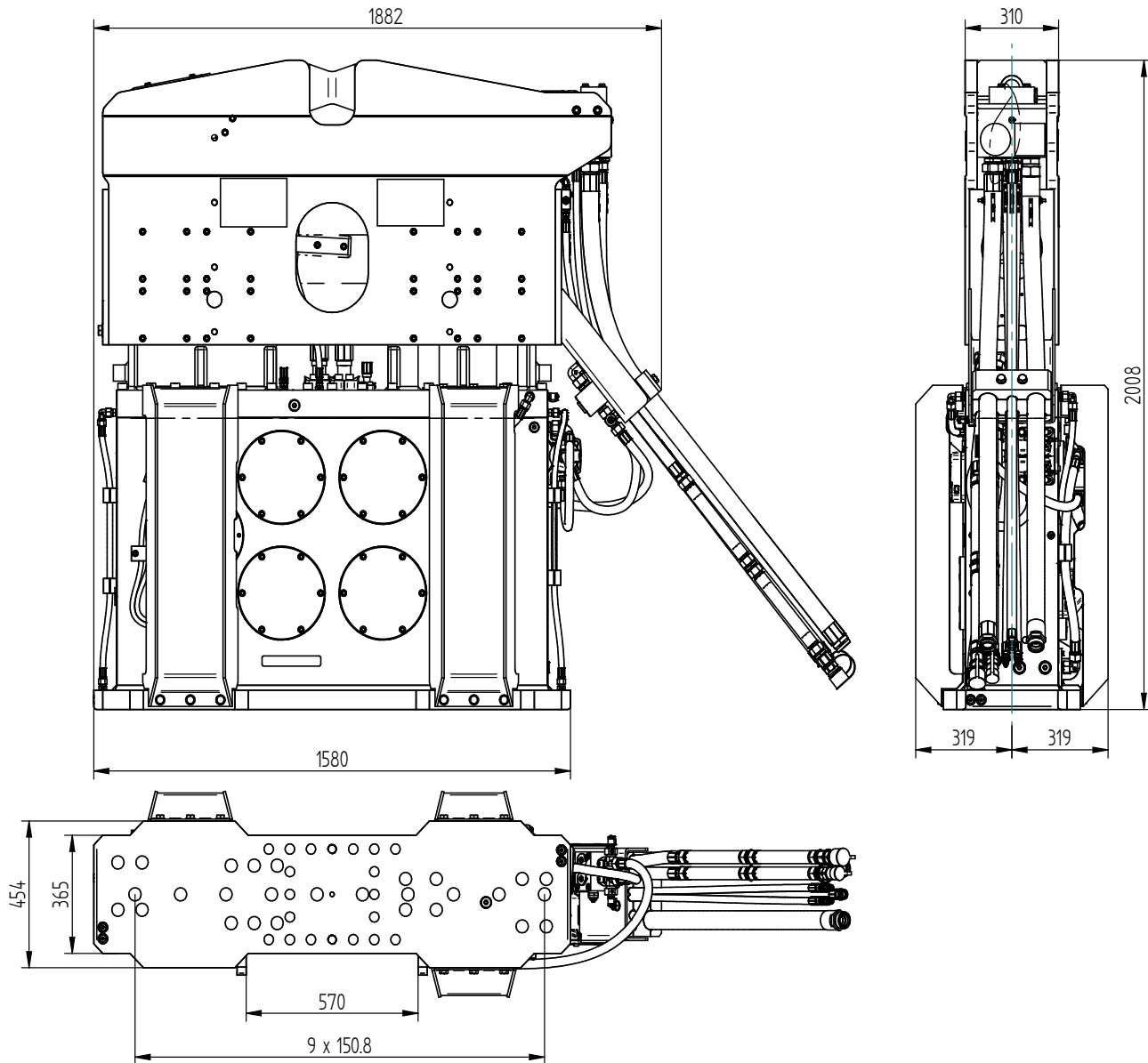

Specificaties

ICE 20RF

Excentrisch moment	0-19 kgm	Klemmen:	
Max. centrifugaalkracht	0-1100 kN	Damwandklem	130TU
Max. toerental	2300 rpm	Transportgewicht per klem	610 kg
Max. amplitude excl. 130TU	15 mm	Pijpenklem	81TC
Max. amplitude incl. 130TU	12 mm	Transportgewicht per klem	480 kg
Max. statische trekkracht	240 kN		
Max. voorspanning	120 kN		
Max. werkdruk	350 bar	Aggregaat:	
Max. oliedoorstroming	498 l/min	Model	500 series
Max. hydraulisch vermogen	291/396 kW/PK		
Geforceerde smering	ja		
Dynamisch gewicht excl. 130TU	2550 kg	Slangenset:	
Dynamisch gewicht incl. 130TU	3160 kg	Lengte	30 m
Totaalgewicht excl. 130TU & slangen	3650 kg	Transportgewicht (±)	615 kg

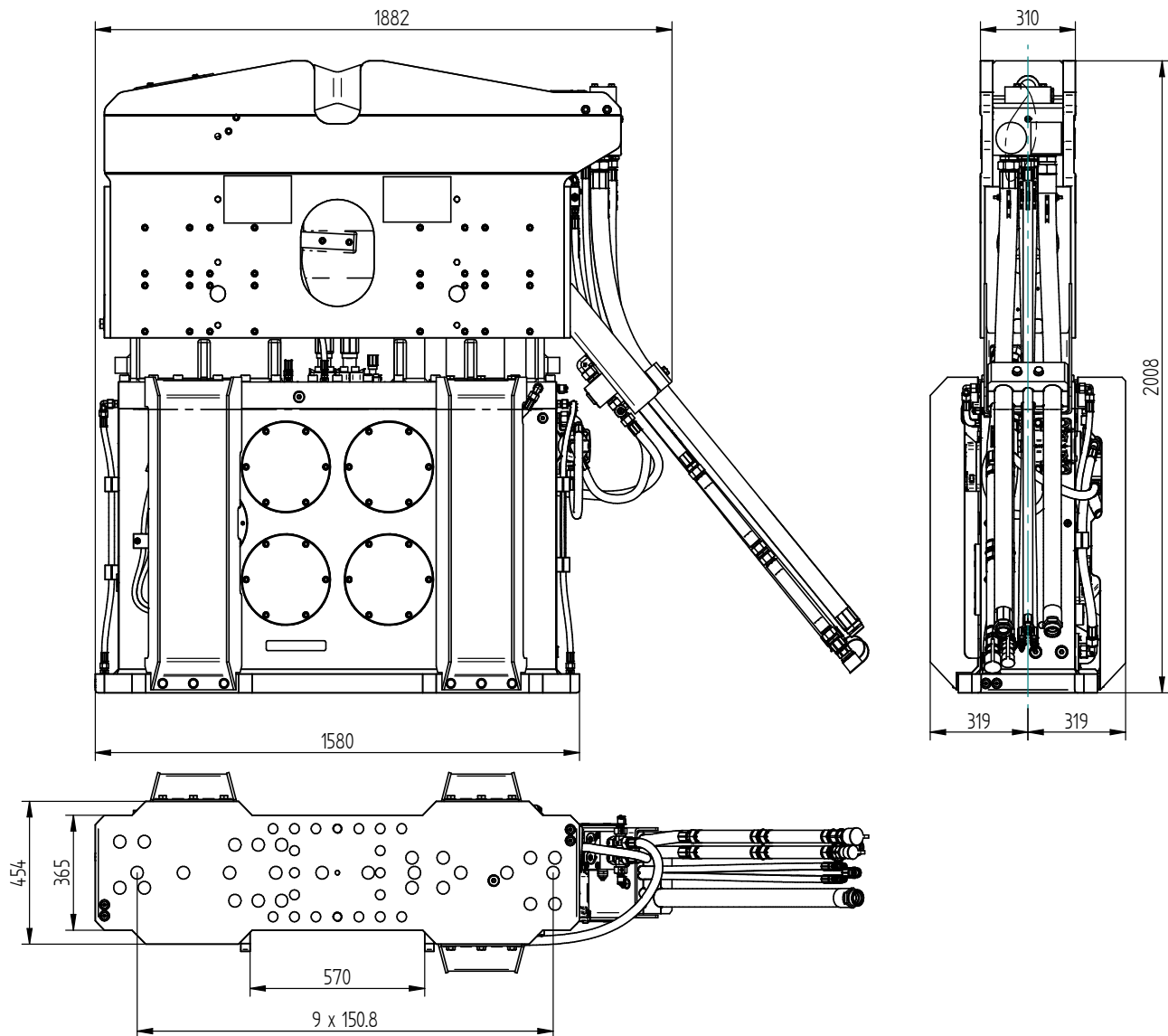

Especificaciones		ICE 20RF	
Momento excéntrico	0-19 kgm	Abrazadera:	
Fuerza centrífuga máxima	0-1100 kN	Hoja abrazadera pila	130TU
Frecuencia máxima	2300 rpm	Peso de transporte por pieza	610 kg
Amplitud máxima excluyendo 130TU	15 mm	Abrazadera de tubo	81TC
Amplitud máxima incluyendo 130TU	12 mm	Peso de transporte por pieza	480 kg
Estático tracción máxima	240 kN		
Compresión máxima	120 kN		
Presión máxima de trabajo	350 bar	Unidad de potencia:	
Flujo de aceite máximo	498 l/min	Modelo	500 series
Máxima potencia hidráulica	291/396 kW/HP		
Lubricación forzada	si		
Peso dinámico excluyendo 130TU	2550 kg	Conjunto de manguera:	
Peso dinámico incluyendo 130TU	3160 kg	Longitud	30 m
Peso total excluyendo 130TU & mangueras	3650 kg	Peso de transporte (±)	615 kg

Dimensions in inches

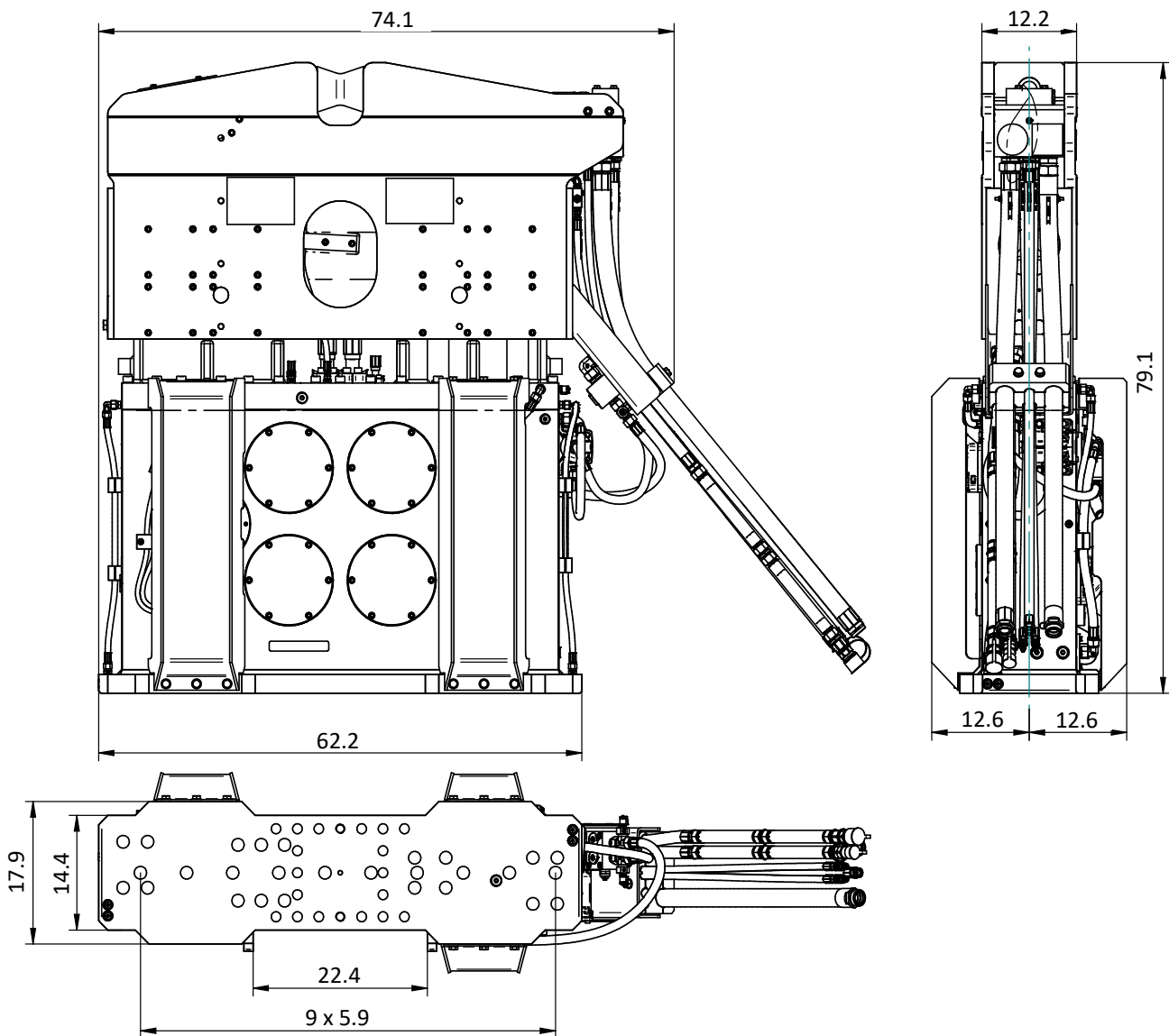

Specifications

ICE 20RF

Eccentric moment	0-1,649 in-lbs	Clamps:	
Max. centrifugal force	0-124 ton	Sheet pile clamp	130TU
Max. frequency	2,300 rpm	Transport weight per piece	1,345 lbs
Max. amplitude excluding 130TU	0.59 in	Double clamps	81TC
Max. amplitude including 130TU	0.47 in	Transport weight per piece	1,058 lbs
Max. static line-pull	24 ton		
Max. pull-down	12 ton		
Max. operating pressure	5,076 psi	Powerpack:	
Max. oil flow	132 gal/min	Model	500 series
Max. hydraulic power	291/396 kW/HP		
Forced lubrication	yes		
Dynamic weight excluding 130TU	5,622 lbs	Hose set:	
Dynamic weight including 130TU	6,967 lbs	Length	98 ft
Total weight excluding 130TU & hoses	8,047 lbs	Transport weight (±)	1,356 lbs

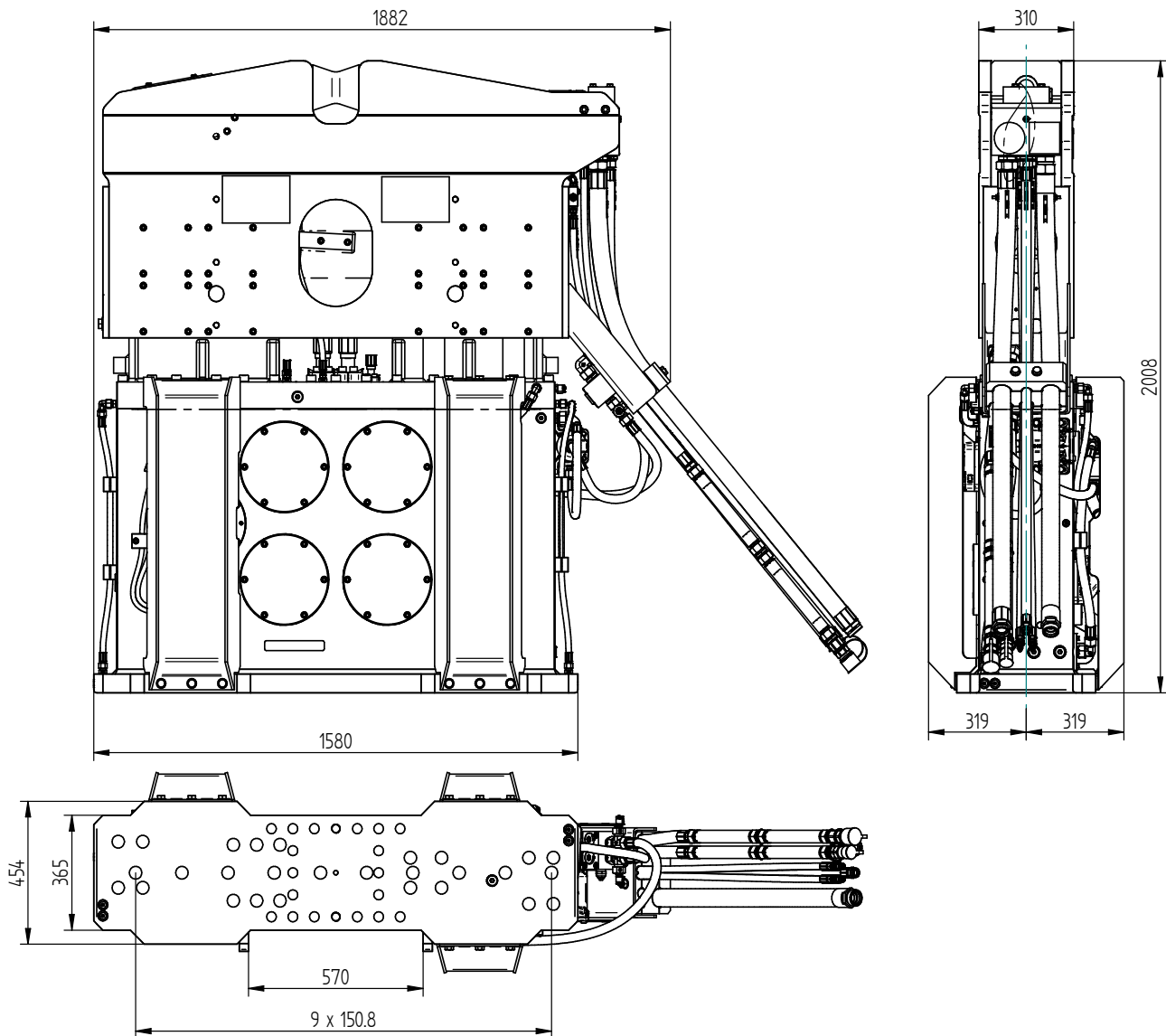
Specificatii :
ICE 20RF

Moment excentric	0-19 kgm	menghira:	
Forta centrifuga maxima	0-1100 kN	menghina pentru palplase	130TU
Frecventa maxima	2300 rpm	Greutatea de transport pp.	610 kg
Amplitudine maxima exclusiva. 130TU	15 mm	menghina dubla	81TC
Amplitudine maxima inclusivă. 130TU	12 mm	Greutatea de transport pp.	480 kg
Tractiune maxima statica	240 kN		
Trage în jos maxima	120 kN		
Presiune maxima de lucru	350 bar	generatoare:	
Debit maxim de ulei	498 l/min	Model	500 series
Puterea hidraulică maxima	291/396 kW/HP		
Lubrifiere fortata	da		
Greutatea dinamica exclusiva. 130TU	2550 kg	Tip de furtun:	
Greutatea dinamica inclusivă. 130TU	3160 kg	Lungimea	30 m
Greutatea totala fara. 130TU si furtun	3650 kg	Greutatea de transport (±)	615 kg