



Specification sheet

PVE 130M

Vibro Hammer

English

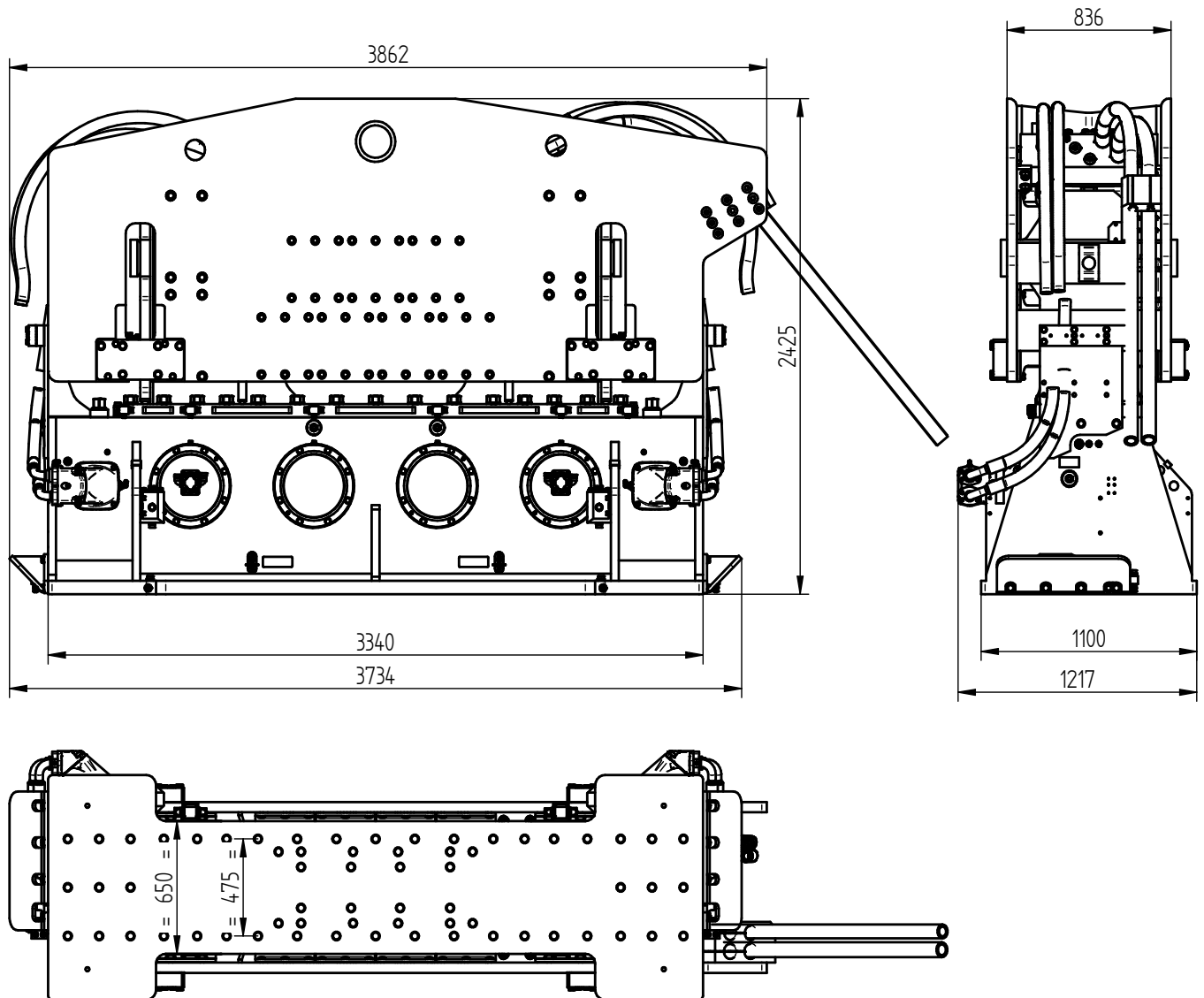

Specifications :

PVE 130M

| | | | |
|----------------------------------|----------------|----------------------------|-------------|
| Eccentric moment | 130 kgm | Clamps: | |
| Centrifugal force | 2794 kN | Sheet pile clamp | 350TU |
| Max. frequency | 1400 rpm | Transport weight per piece | 2600 kg |
| Max. amplitude excl. 350TU | 25 mm | Double clamps | 175TC |
| Max. amplitude incl. 350TU | 22 mm | Transport weight per piece | 1300 kg |
| Max. static line-pull | 1260 kN | | |
| Max. pull-down | 120 kN | | |
| Max. operating pressure | 350 bar | Powerpack: | |
| Max. oil flow | 1293 l/min | Model | 1400 series |
| Max. hydraulic power | 754/1025 kW/HP | | |
| Forced lubrication | yes | | |
| Dynamic weight excl. 350TU | 10420 kg | Hose set: | |
| Dynamic weight incl. 350TU | 13020 kg | Length | 60 m |
| Total weight excl. 350TU & hoses | 16900 kg | Transport weight (±) | 1640 kg |