



Specification sheet

PVE 150M

Vibro Hammer

English

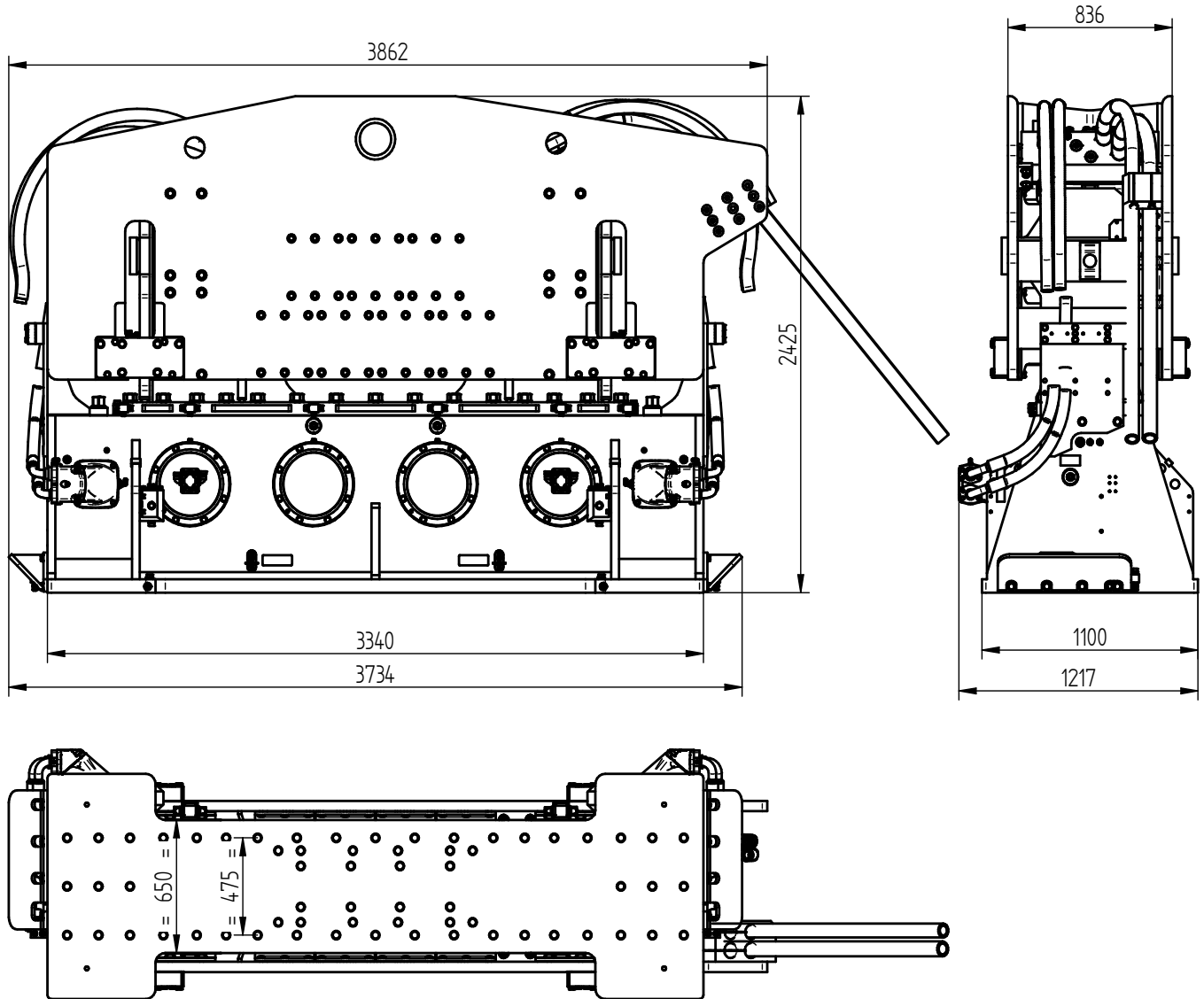

Specifications :

PVE 150M

Eccentric moment	150 kgm	Clamps:	
Centrifugal force	3224 kN	Double clamps	200TC
Max. frequency	1400 rpm	Transport weight per piece	1350 kg
Max. amplitude excl. 200TC (2x)	26,3 mm		
Max. amplitude incl. 200TC (2x)	21,3 mm		
Max. static line-pull	1260 kN		
Max. pull-down	120 kN		
Max. operating pressure	350 bar	Powerpack:	
Max. oil flow	1293 l/min	Model	1400 series
Max. hydraulic power	754/1025 kW/HP		
Forced lubrication	yes		
Dynamic weight excl. 200TC (2x)	11400 kg	Hose set:	
Dynamic weight incl. 200TC (2x)	14100 kg	Length	60 m
Total weight excl. 200TC (2x) & hoses	17780 kg	Transport weight (±)	1640 kg