



# Specification sheet

## PVE 170M

Vibro Hammer

English

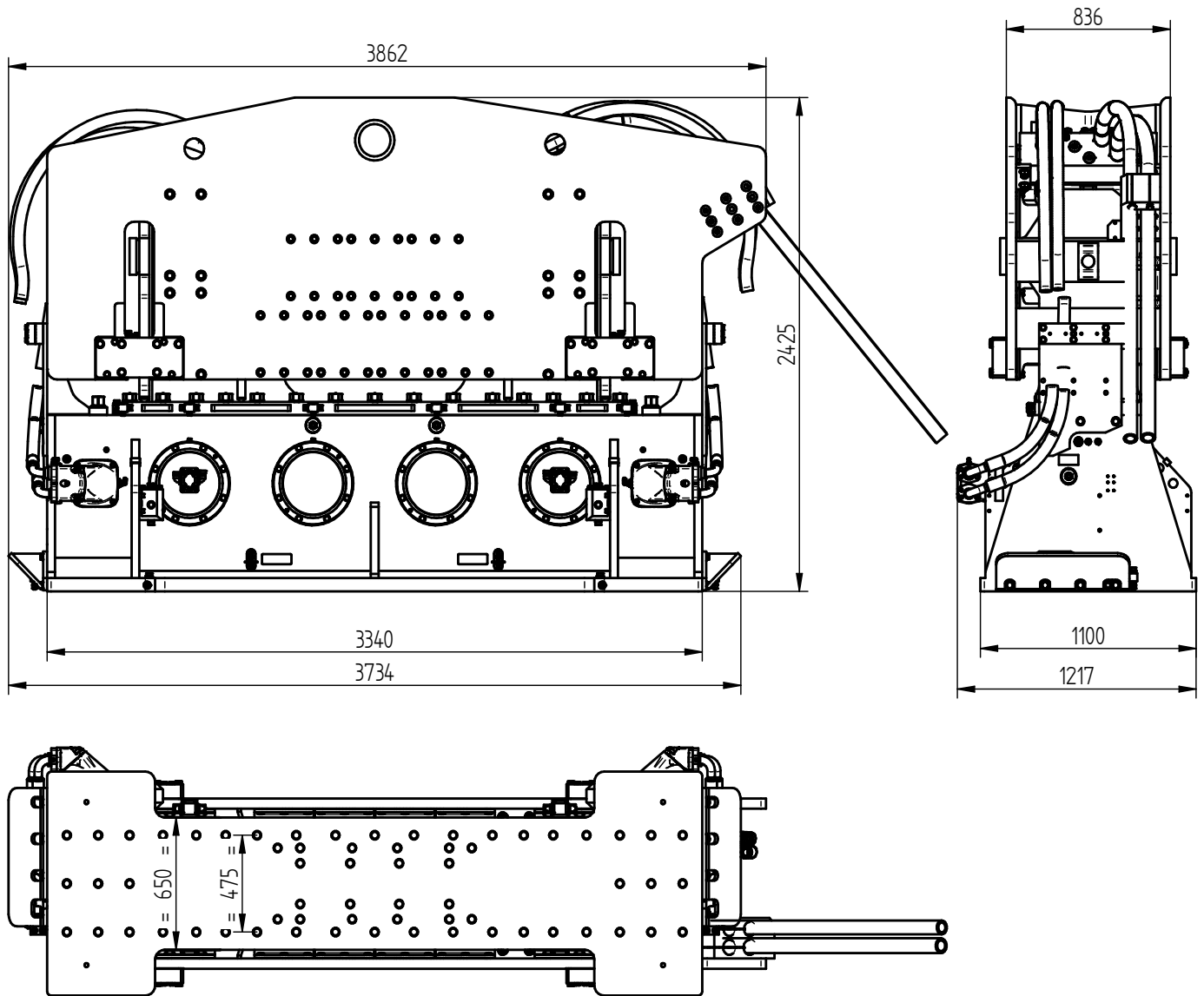

### Specifications :

### PVE 170M

Eccentric moment	170 kgm	<b>Clamps:</b>	
Centrifugal force	3654 kN	Double clamps	350TC (2x)
Max. frequency	1400 rpm	Transport weight per piece	2980 kg
Max. amplitude excl. 350TC (2x)	29,7 mm		
Max. amplitude incl. 350TC (2x)	19,5 mm		
Max. static line-pull	1260 kN		
Max. pull-down	120 kN		
Max. operating pressure	350 bar	<b>Powerpack:</b>	
Max. oil flow	1293 l/min	Model	1400 series
Max. hydraulic power	754/1025 kW/HP		
Forced lubrication	yes		
Dynamic weight excl. 350TC (2x)	11455 kg	<b>Hose set:</b>	
Dynamic weight incl. 350TC (2x)	17415 kg	Length	60 m
Total weight excl. 350TC (2x) & hoses	17850 kg	Transport weight (±)	1640 kg