

### Specifications

Eccentric moment:	11	kgm
Max. frequency:	1800	rpm
Centrifugal force:	388	kN
Line Pull Cap.:	500	kN
Amplitude: (at tip)	24	mm
Total weight: (inc 1 follower)	5160	kg
Follower Weight: (per piece L=5,5 m)	1900	kg
Flow:	450	l/min
Max Pressure:	350	Bar

Main parts:	Pos.	
Heavy duty isolator	1	
Motor	2	
Eccentric wear parts	3	
Water jet pipe	4	
Nose cone	5	
Follower tube	6	
Hose guide	7	
Lifting head	8	

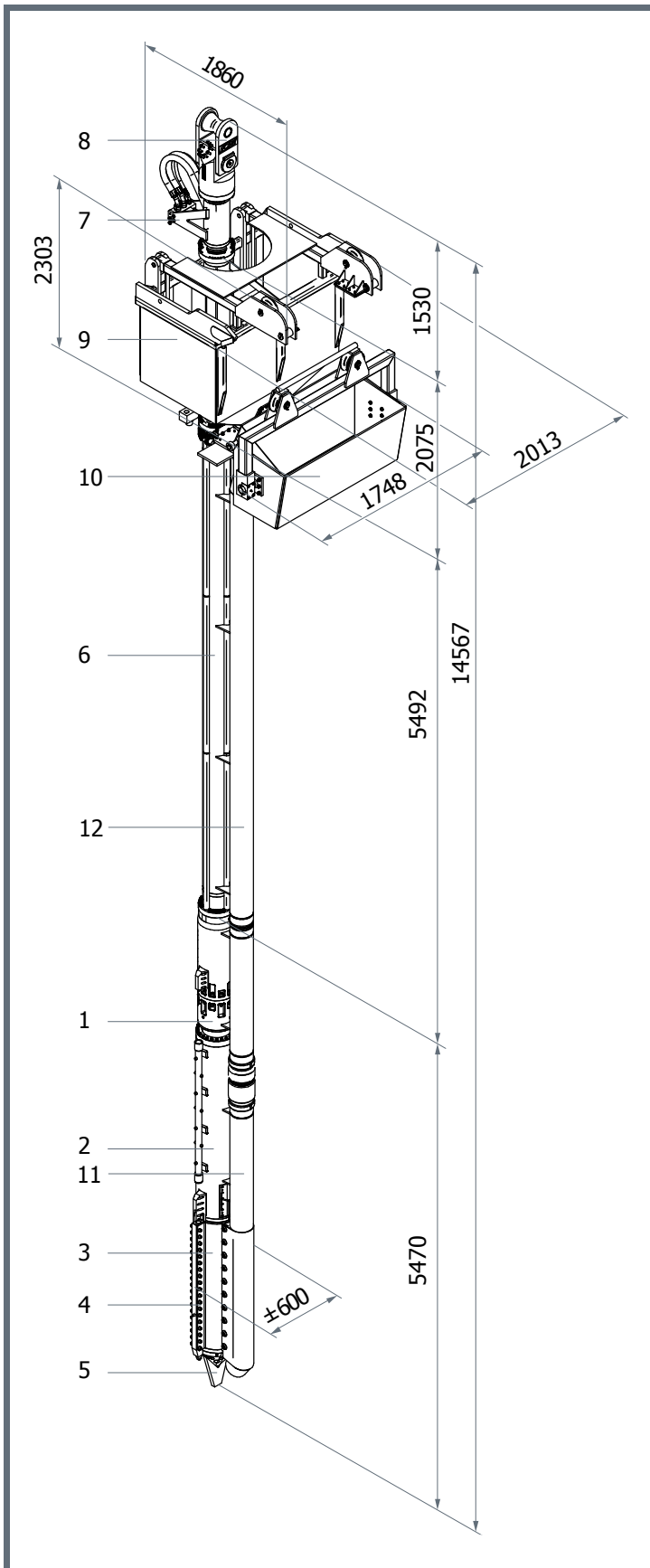

**Specifications**

Eccentric moment:	11	kgm
Max. frequency:	1800	rpm
Centrifugal force:	388	kN
Line Pull Cap.:	500	kN
Amplitude: (at tip)	24	mm
Total weight: (inc 1 follower)	10100	kg
Follower Weight: (per piece L=5,5 m)	2260	kg
Volume stone funnel	1.73	m <sup>3</sup>
Volume stone hopper	0.625	m <sup>3</sup>
Flow:	450	l/min
Max Pressure:	350	Bar

Main parts:	Pos.	
Heavy duty isolator	1	
Motor	2	
Eccentric wear parts	3	
Water jet pipe	4	
Nose cone	5	
Follower tube	6	
Hose guide	7	
Lifting head	8	
Stone funnel	9	
Stone hopper	10	
Stone pipe	11	
Stone follower	12	